

SECTION 8

CLASSIC PUMPS

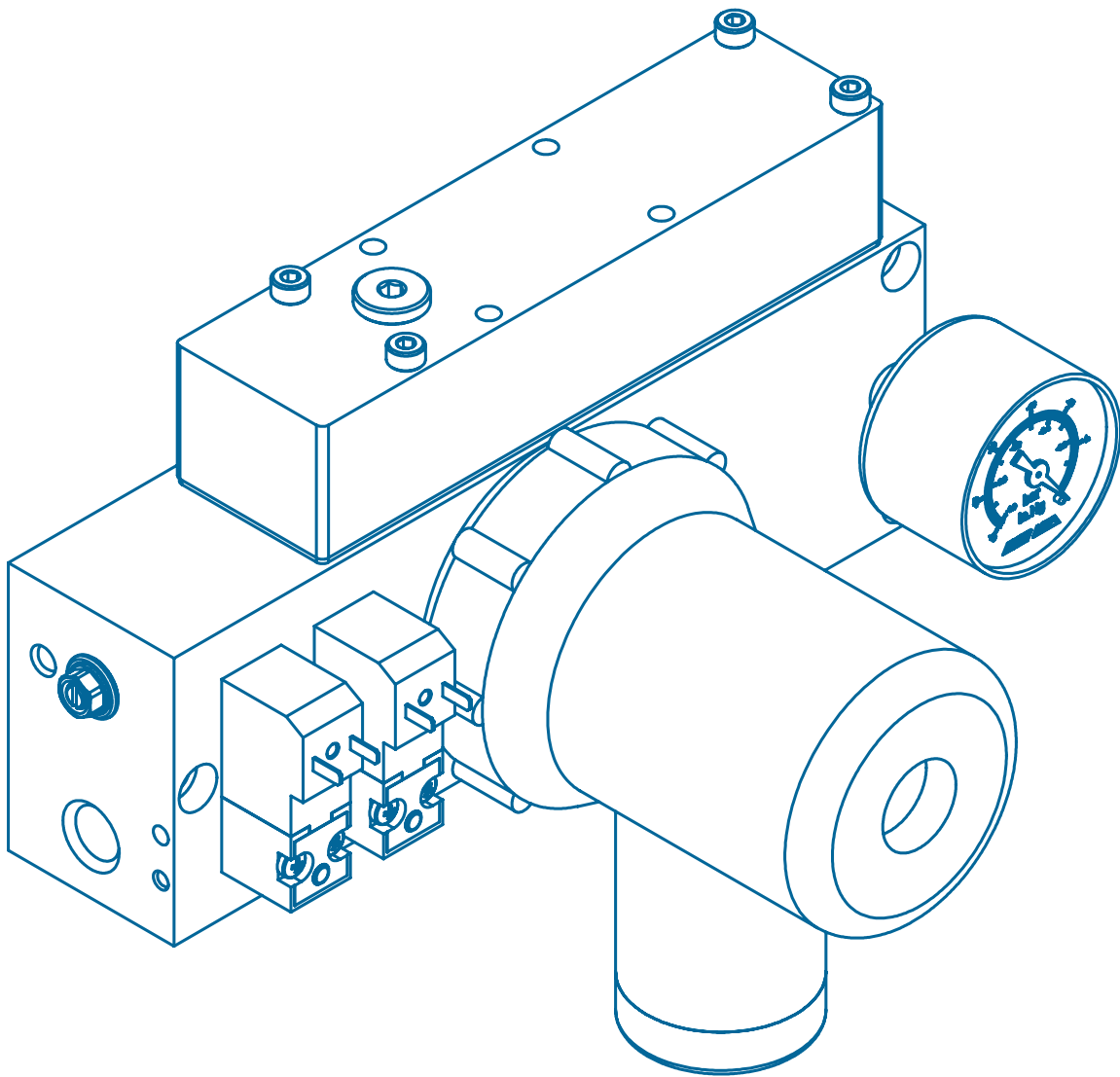

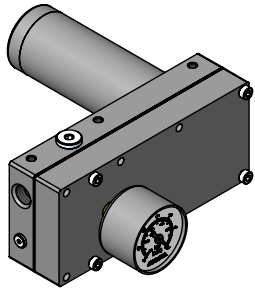

Basic

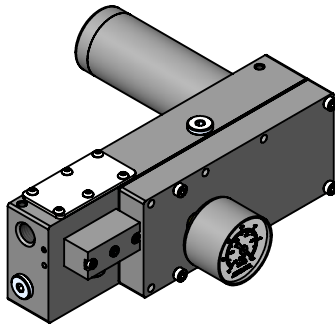

Control Options

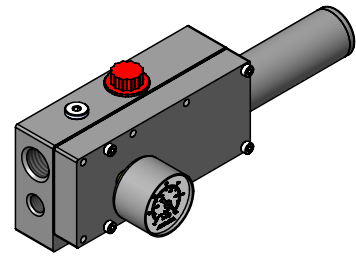

SM & SMS

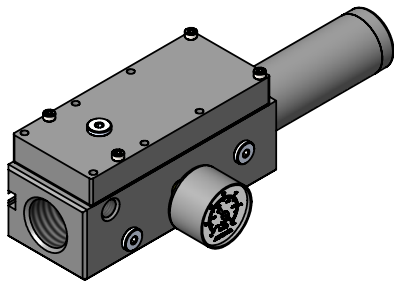

6010 & 6034

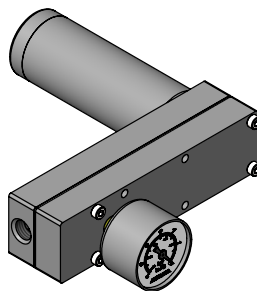

Mini-Classic

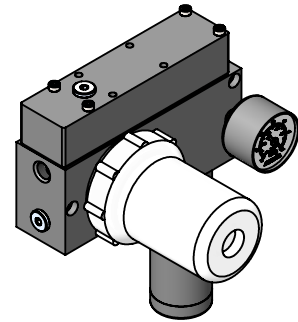

Integrated Filter

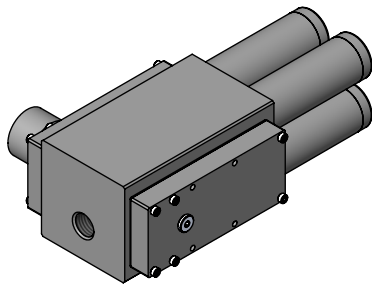

Dual-Base

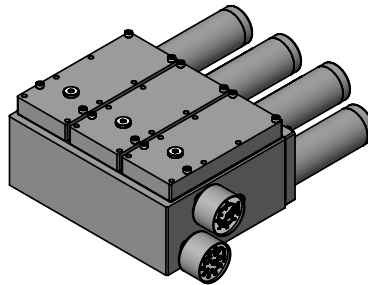

Triple-Base

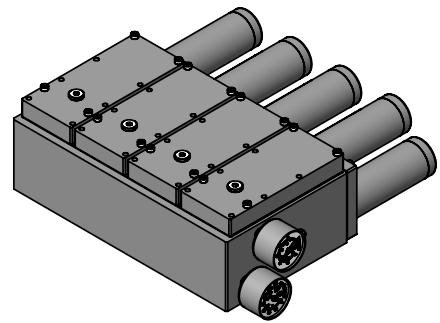

Quadruple-Base

Information	3
Basic	4
Control Options	5-8
Mount Options	9
SM Base	10
6010 & 6034 Base	11-12
Classic Pumps w/ Integrated Filter	13-17
Mini-Classic Pumps	18
Dual-Base Classic Pumps	19
Triple / Quad Base Classic Pumps	20-22
Performance	22-28

Classic Series Pumps: Principles of Operation

Mult-Ejector

Larger capacity vacuum pumps are created by placing identical nozzle sets in a parallel configuration, either in the same body or in a stacking module. Additional vacuum flow capacity is attained but maximum vacuum level is not affected since that is determined by the nozzle series. This method provides a specific repeatable increment of capacity increase that is very handy when sizing a pump for an application since the basic shape of the performance curve doesn't change. Vacuum flow and air consumption is increased in proportion to the number of nozzle sets, and system evacuation time is decreased proportionately.

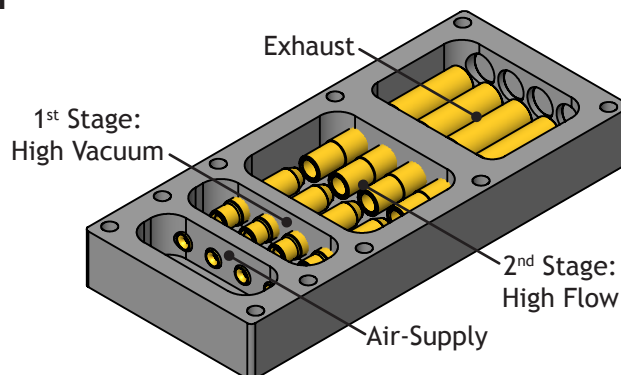

High-Flow Mode

An air supply to the pump is turned on and high-pressure air flows thru the first nozzle, generating a vacuum flow when it passes into the second nozzle. As air is evacuated from the system, induced air flows into the vacuum port and is drawn into the first stage ejector (gap between first and second nozzles) and combines with the compressed air flow from the first nozzle before passing into the second stage ejector (gap between second and third nozzle). The powerful combined airflow induces a high vacuum flow rate thru the second stage ejector until the increasing vacuum level causes the flap check valve to close. The valve closing point is dependent on nozzle series (A, E, L, M, ML, or X) and the operating air pressure. For example at 87 psi the flap valve will close at 11 inHg for an ML-series pump and at 18 inHg for an E-series pump. This closing is evident by the change in slope of the performance curve.

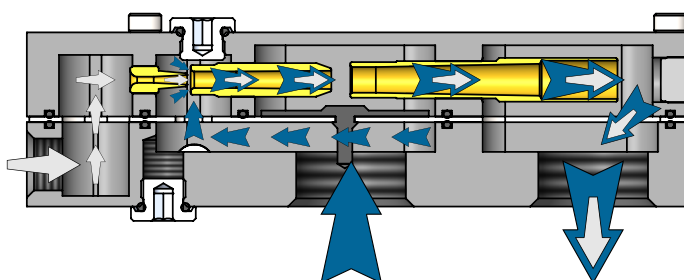

High-Vacuum Mode

After the flap valve closes, induced air continues to be drawn into the first stage ejector and the vacuum level will increase to the maximum level allowed by the nozzle series. At this point the second stage is isolated and is not contributing to evacuation of the system. Some of our competitors offer three and four stage vacuum pumps but these provide very little benefit for industrial systems since a third stage will shut down at 3 inHg and a fourth stage will shut down at 1.5 inHg. EDCO nozzles are optimized to give extra vacuum flow at higher vacuum levels to more-than make up for lower flows from zero to 3 inHg. EDCO evacuation times to 12 inHg or higher will be equal or better than our competition.

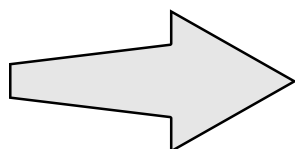
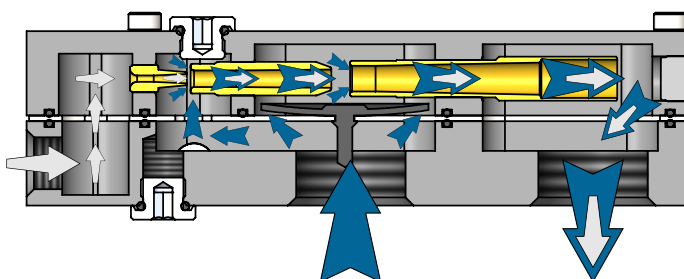

Compressed Air Flow

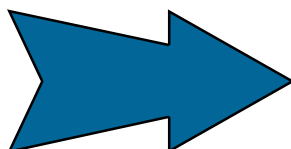

Induced Vacuum Flow

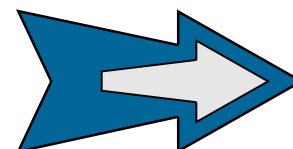

Exhaust Flow

Classic Series Pumps: Basic Pump

Basic pump controlled via air supply through the pump base inlet port.

Series	Capacity	Seal	Ports		Valve Options		Filter Option	
ML	100	N						
E	25 (40)	E EPDM	(Blank)	NPTF Threads	(Blank)	Standard	(Blank)	Standard
L	50 (80)	N Nitrile	-G	G Threads	-NR	Non-Return	-PFC	Filter Combo
M	75 (120)	S Silicone			-LV	No Valve		
ML	100 (160)	V Viton ²						

(X Series)

125 (200)
150 (240)
175 (280)
200 (320)

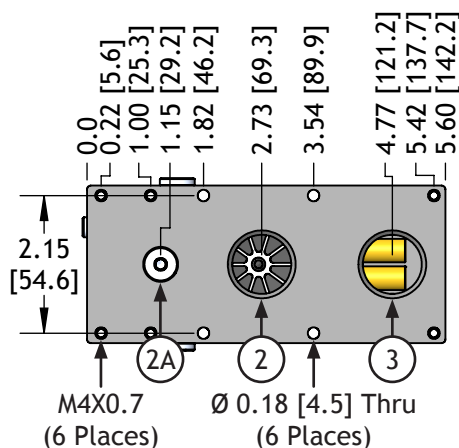
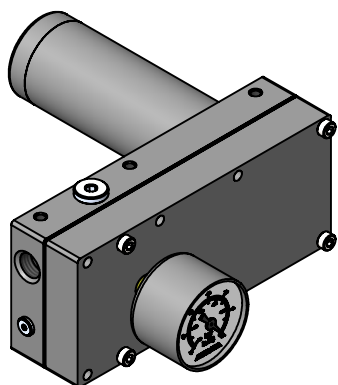
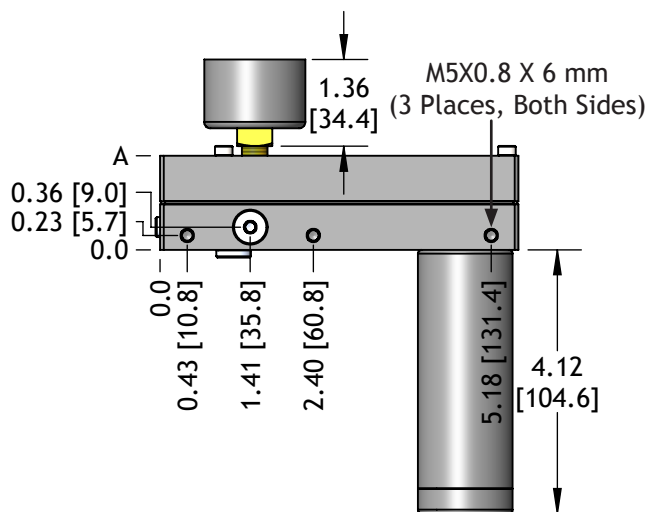
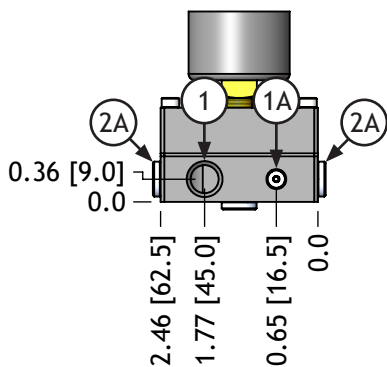
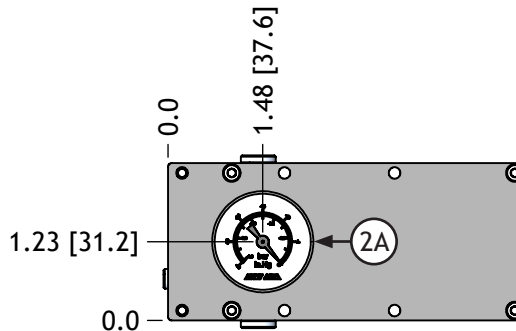

Code	Function	NPTF	G
1	Air-Supply	1/4 NPTF	G 1/4
1A	Alternate Air-Supply	M5X0.8 (10-32)	
2	Vacuum	3/4 NPTF	G 3/4
2A	Alternate Vacuum	G 1/8 NPSF	
3	Exhaust	3/4 NPTF	G 3/4

Capacity	A in [mm]	A - Weight lb [g]
25-100	1.47 [37.3]	1.63 [739]
125-200	2.18 [55.4]	2.21 [1002]

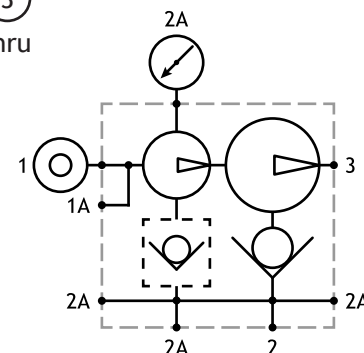

Classic Series Pumps: Piloted Air-Supply (-2PS)

The pump base contains an integral, pilot-operated, 3-way air valve which controls vacuum on/off via pneumatic pilot signal. When the pilot signal is presented, the vacuum is turned on. When the pilot signal is exhausted, the pump turns off.

Series	Capacity	Seal	Ports		Valve Options		Filter Option	
ML	100	N	-2PS		(Blank)	Standard	(Blank)	Standard
E	25 (40)	E	EPDM	(Blank) NPTF Threads	-NR	Non-Return	-PFC	Filter Combo
L	50 (80)	N	Nitrile	-G G Threads	-LV	No Valve		
M	75 (120)	S	Silicone					
ML	100 (160)	V	Viton ²					

(X Series)

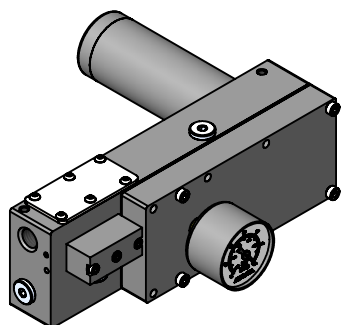
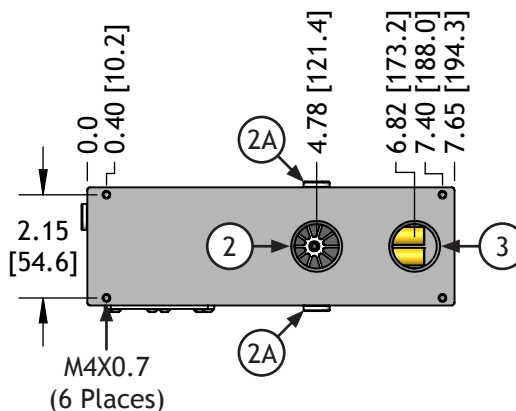
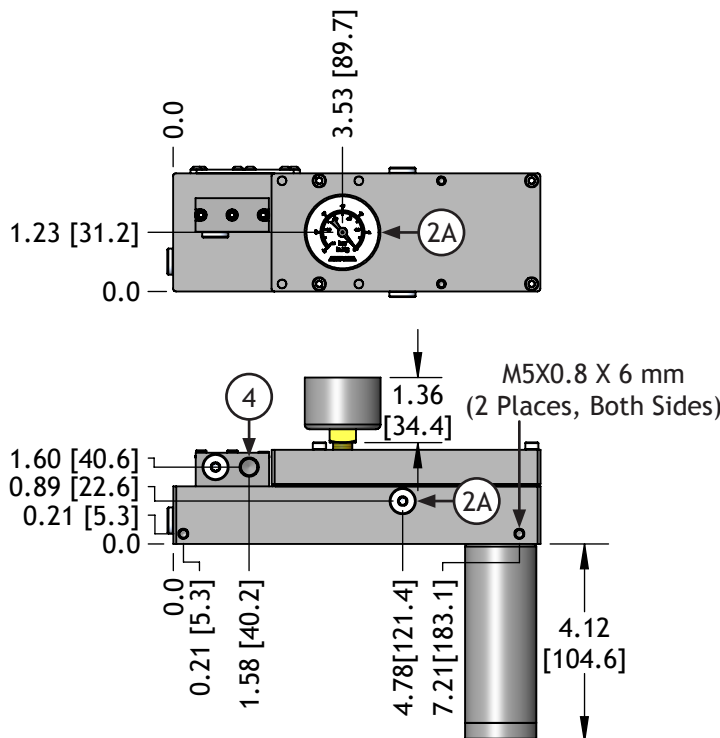
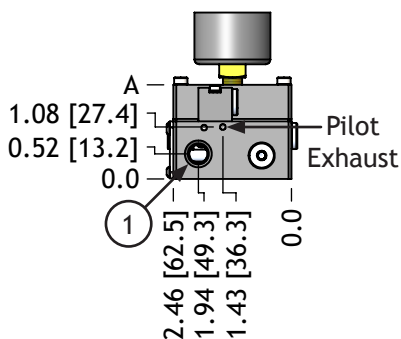

Code	Function	NPTF	G
1	Air-Supply	1/4 NPTF	G 1/4
2	Vacuum	3/4 NPTF	G 3/4
2A	Vacuum - Alternate	G 1/8 NPSF	
3	Exhaust	3/4 NPTF	G 3/4
4	Pilot Signal - Air-Supply	G 1/8 NPSF	

Capacity	A in [mm]	A - Weight lb [g]
25-100	1.96 [49.8]	2.81 [1275.0]
125-200	2.67 [67.8]	3.41 [1547.0]

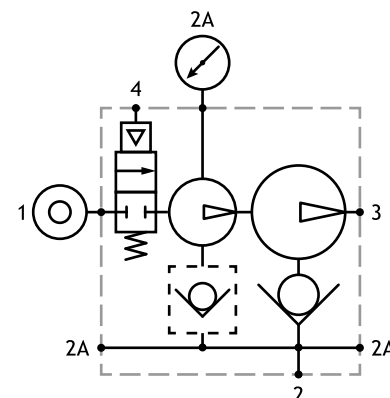

Classic Series Pumps: Piloted Air-Supply & Blow-Off (-2PSB)

The pump base contains two integral, pilot-operated, 3-way air valves which provide full pump control via two externally supplied pneumatic pilot signals. With a constant air-supply to the pump base, one pilot signal controls vacuum on/off while a second pilot signal controls blow-off air to dissipate vacuum for faster system cycle time.

Series	Capacity	Seal	Ports	Valve Options	Filter Option
ML	100	N	-2PSB		
E	25 (40)	E EPDM	(Blank) NPTF Threads	(Blank) Standard	(Blank) Standard
L	50 (80)	N Nitrile	-G G Threads	-NR Non-Return	-PFC Filter Combo
M	75 (120)	S Silicone		-LV No Valve	
ML	100 (160)	V Viton ²			

X	125 (200)
	150 (240)
	175 (280)
	200 (320)

(X Series)

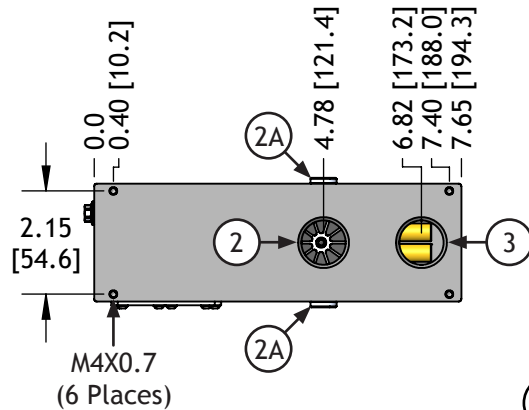
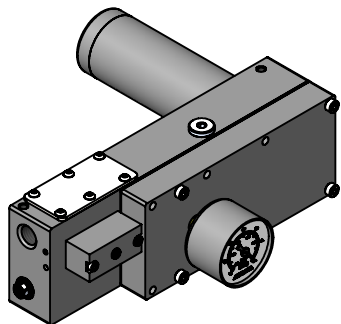
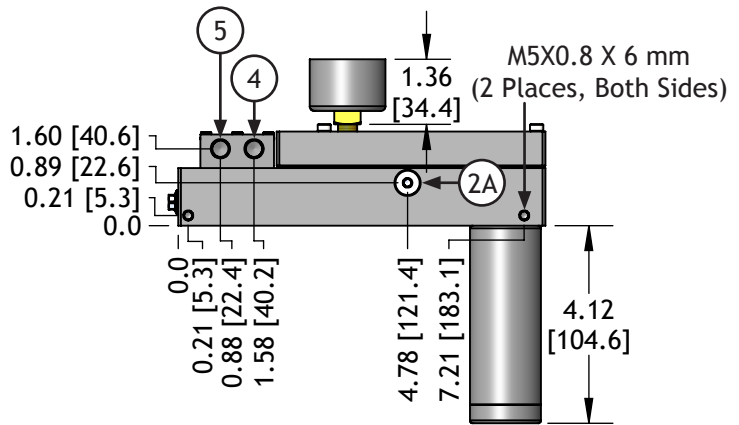
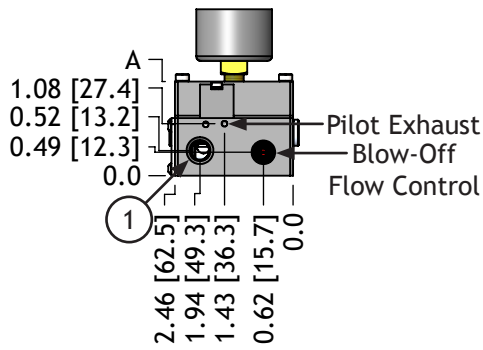
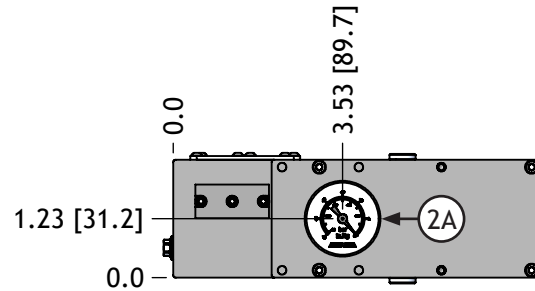

Capacity	A in [mm]	A - Weight lb [g]
25-100	1.96 [49.8]	2.81 [1275.0]
125-200	2.67 [67.8]	3.41 [1547.0]

Code	Function	NPTF	G
1	Air-Supply	1/4 NPTF	G 1/4
2	Vacuum	3/4 NPTF	G 3/4
2A	Vacuum - Alternate	G 1/8 NPSF	
3	Exhaust	3/4 NPTF	G 3/4
4	Pilot Signal - Air-Supply	G 1/8 NPSF	
5	Pilot Signal - Blow-Off	G 1/8 NPSF	

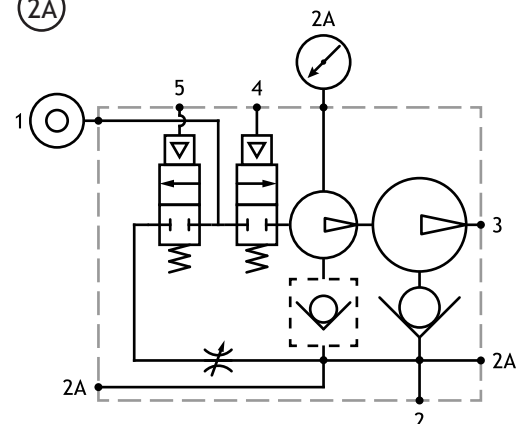

Classic Series Pumps: Solenoid Controlled Air-Supply

The pump base contains an integral, pilot-operated, 3-way air valve which controls vacuum on/off via a solenoid valve. When the solenoid valve is energized, the vacuum pump turns on. When the solenoid valve is de-energized, the pump turns off.

-2S24D: 24V DC, 2.3 W Solenoid Control Valve (-2OS24D for N.O. Supply)

-2S110A: 20V AC 60 Hz (110V AC 50 Hz), 2.3 W Solenoid Control Valve (-2OS110A for N.O. Supply)

Series	Capacity	Seal	Ports	Solenoid Option	Valve Options	Filter Option
ML	100	N		-2S24D		
E	25 (40)	E EPDM	(Blank) NPTF Threads	-2S24D	(Blank) Standard	(Blank) Standard
L	50 (80)	N Nitrile	-G G Threads	-2S110A	-NR Non-Return	-PFC Filter Combo
M	75 (120)	S Silicone		-2OS24D	-LV No Valve	
ML	100 (160)	V Viton ²		-2OS110A		

X	125 (200)
	150 (240)
	175 (280)
	200 (320)

(X Series)

Order DIN T-9 Molded Cords Separately:

923-2M01: Std. 2M

923-2M31: L.E.D. 0-50V, 2M

923-2M81: L.E.D.70-250V, 2M

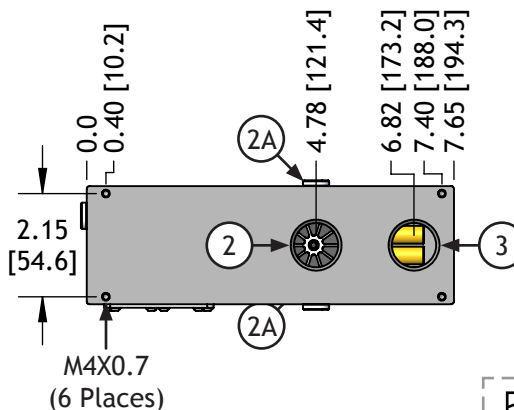
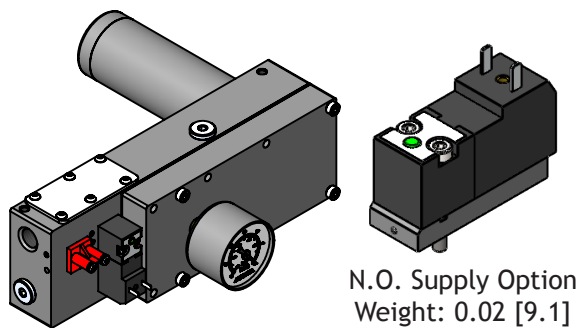
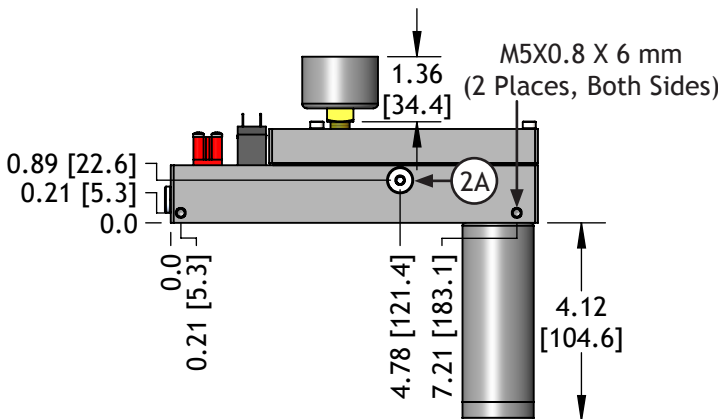
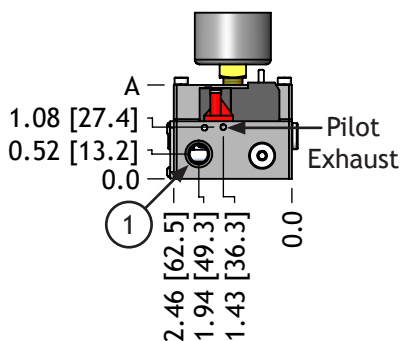
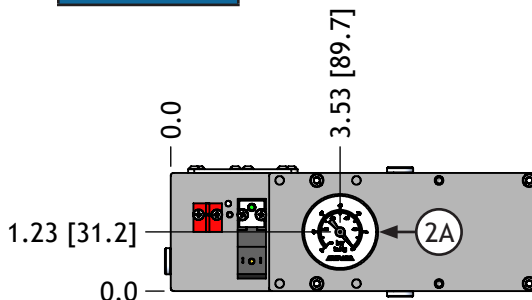

Capacity	A in [mm]	A - Weight lb [g]
25-100	1.96 [49.8]	2.87 [1301.0]
125-200	2.67 [67.8]	3.47 [1574.0]

Code	Function	NPTF	G
1	Air-Supply	1/4 NPTF	G 1/4
2	Vacuum	3/4 NPTF	G 3/4
2A	Vacuum - Alternate	G 1/8 NPSF	
3	Exhaust	3/4 NPTF	G 3/4

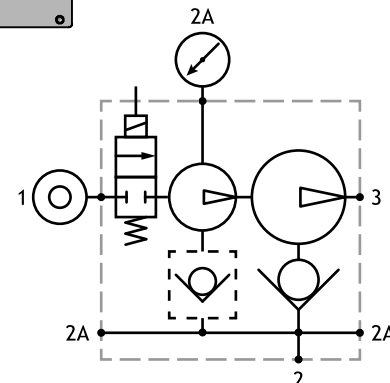

Classic Series Pumps: Solenoid Controlled Air-Supply & Blow-Off

The pump base contains two integral, pilot-operated, 3-way air valves which provide full pump control via two solenoid valves. With a constant air-supply to the pump base, one solenoid valve controls vacuum on/off while a second solenoid valve controls blow-off air to dissipate vacuum for faster system cycle time.

-2SB24D: 24V DC, 2.3 W Solenoid Control Valve (-2OSB24D for normally open supply)

-2SB110A: 20V AC 60 Hz (110V AC 50 Hz), 2.3 W Solenoid Control Valve (-2OS110A for normally open supply)

Series	Capacity	Seal	Ports	Solenoid Option	Valve Options	Filter Option
ML	100	N		-2SB24D		
E	25 (40)	E EPDM	(Blank) NPTF Threads	-2BS24D	(Blank) Standard	(Blank) Standard
L	50 (80)	N Nitrile	-G G Threads	-2SB110A	-NR Non-Return	-PFC Filter Combo
M	75 (120)	S Silicone		-2OSB24D	-LV No Valve	
ML	100 (160)	V Viton ²		-2OSB110A		
X	125 (200)					
	150 (240)					
	175 (280)					
	200 (320)					

(X Series)

Order DIN T-9 Molded Cords Separately:

923-2M01: Std. 2M

923-2M31: L.E.D. 0-50V, 2M

923-2M81: L.E.D.70-250V, 2M

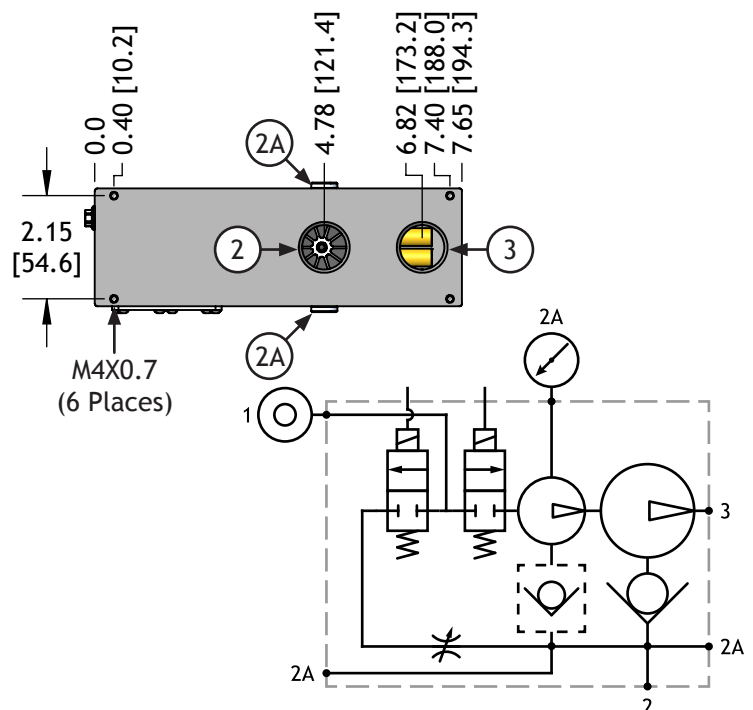
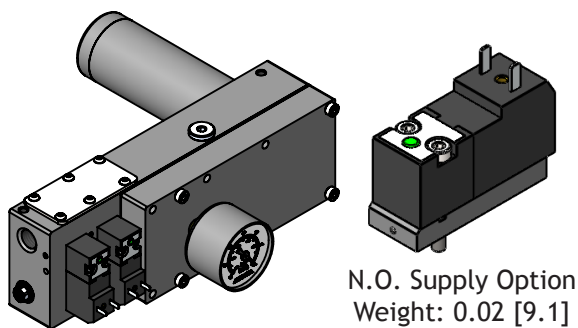
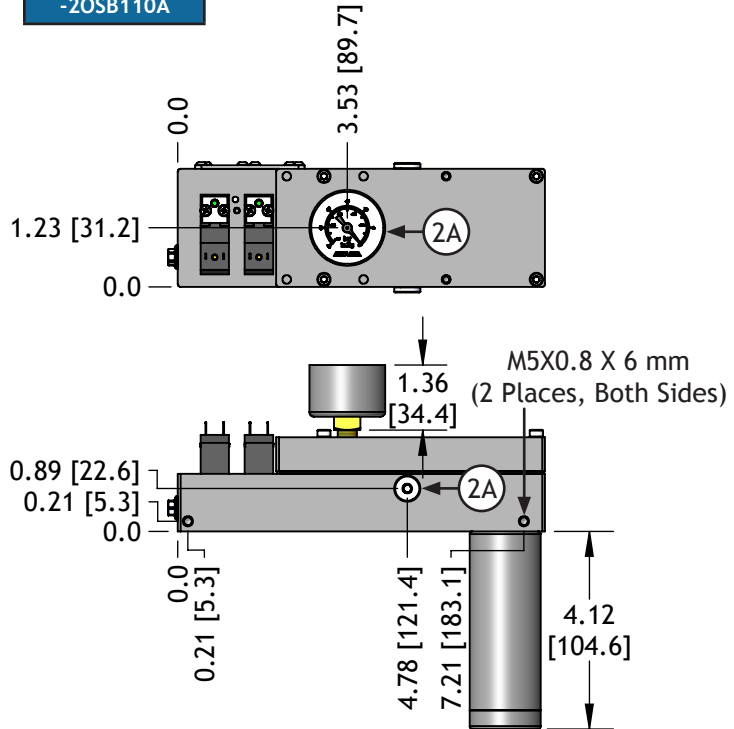
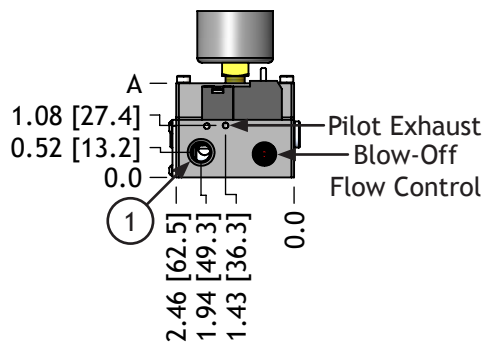

Capacity	A in [mm]	A - Weight lb [g]
25-100	1.96 [49.8]	2.81 [1275.0]
125-200	2.67 [67.8]	3.41 [1547.0]

Code	Function	NPTF	G
1	Air-Supply	1/4 NPTF	G 1/4
2	Vacuum	3/4 NPTF	G 3/4
2A	Vacuum - Alternate	G 1/8 NPSF	
3	Exhaust	3/4 NPTF	G 3/4

Classic Series Pumps: Mounting Brackets

Stainless steel mounting brackets come in 90° and 180° styles to use in a variety of mounting options. ML-BKT-90 and ML-BKT-180 can be used in side or end orientation on the basic classic pump base and end orientation on pump bases with air-supply or blow-off control options. Dual hole patterns provide attachment to both metric and inch structural framing extrusion t-slots.

Weight: 0.06 lbs [131.1 g]

Brackets and fastener kits must be ordered separately. Not available for 6010, 6034, SM, or SMS bases.

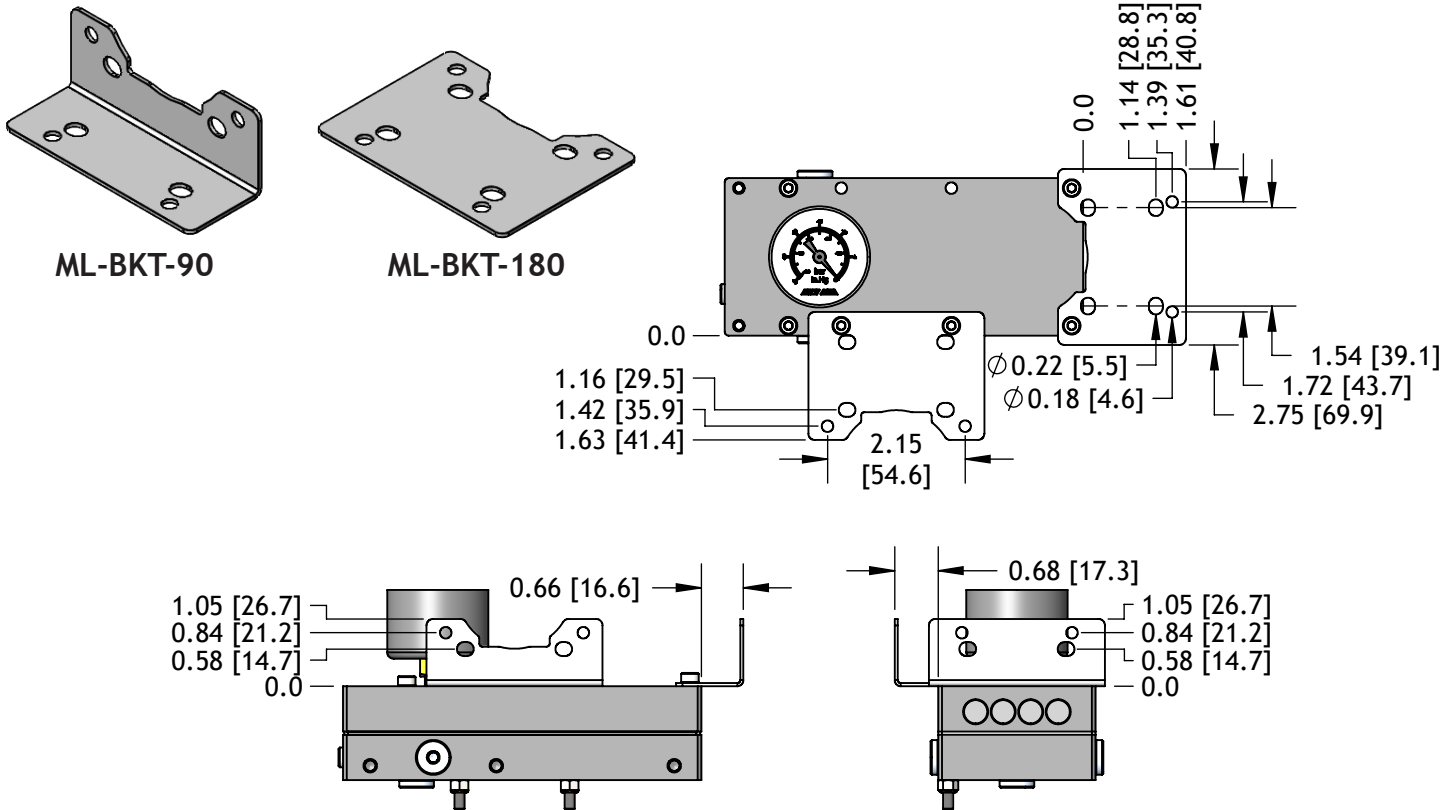

Fastener Kits

Fastener Kit	Function	NPTF
ML-M4-E1	End Mount, 25-100 Capacity	M4X10 (2) & M4X30 (2)
ML-M4-E2	End Mount, 125-200 Capacity	M4X10 (2) & M4X50 (2)
ML-M4-S1	Side Mount, 25-100 Capacity	M4X50 (2) & M4 Nut (2)
ML-M4-S2	Side Mount, 125-200 Capacity	M4X70 (2) & M4 Nut (2)

Classic Series Pumps: SM Base

The SM (surface mount) base includes 1/2" vacuum ports at three locations and a flat backside for panel mounting. One to three vacuum lines can be ran directly from the pump base. Unused vacuum ports simply need to be plugged. This design makes this pump configuration ideal for robotic end-effectors.

Series	Capacity	Seal	Ports	Gauge Option	Valve Options	Filter Option
ML	100	N		-SM		
E	25 (40)	E EPDM	(Blank) NPTF Threads	-SM Standard	(Blank) Standard	(Blank) Standard
L	50 (80)	N Nitrile	-G G Threads	-SMS Side Gauge	-NR Non-Return	-PFC Filter Combo
M	75 (120)	S Silicone			-LV No Valve	
ML	100 (160)	V Viton ²				
X	125 (200)					

150 (240)
175 (280)
200 (320)

(X Series)

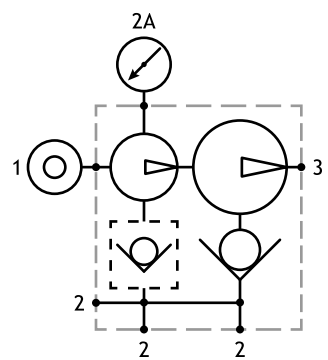
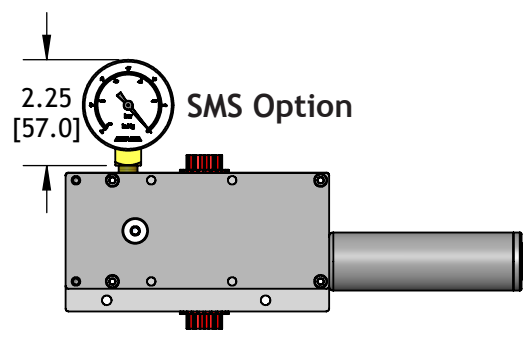
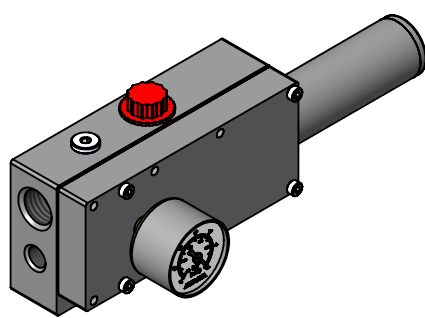
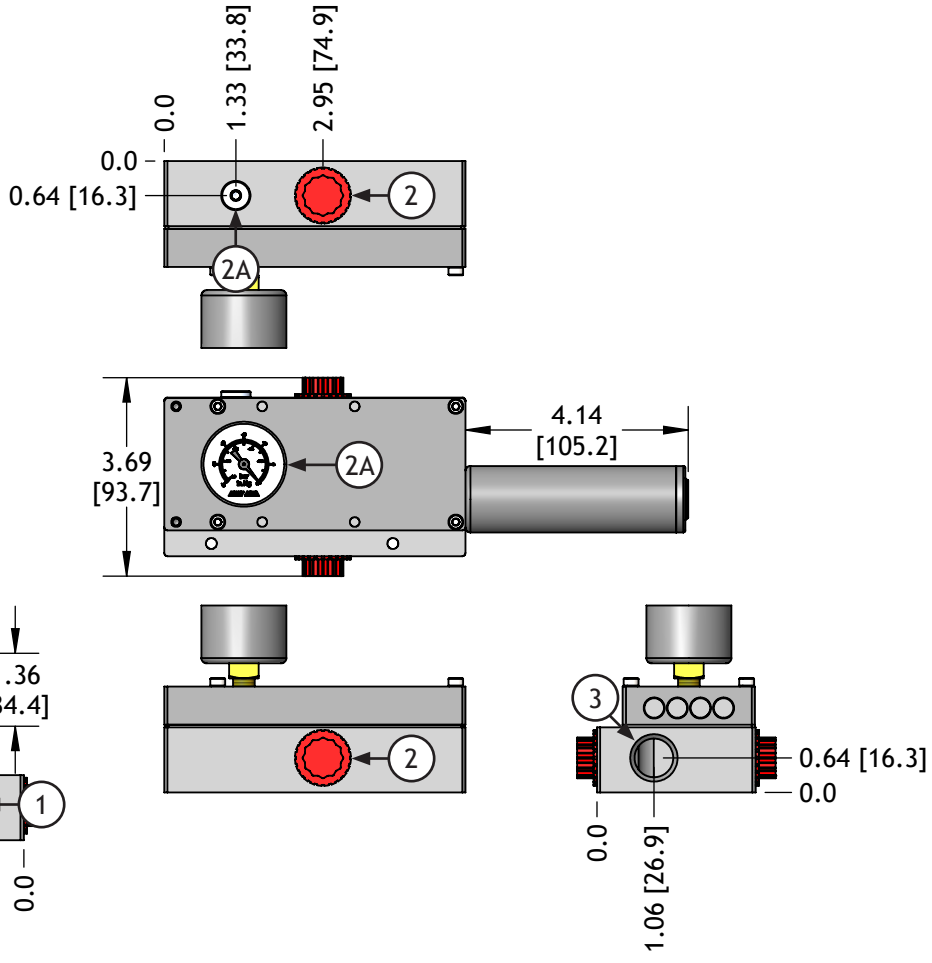

Code	Function	NPT	G
1	Air-Supply	1/4 NPTF	G 1/4
2	Vacuum	3/4 NPTF	G 3/4
2A	Vacuum - Alternate	G 1/8 NPSF	
3	Exhaust	1/2 NPTF	G 1/2

Capacity	A in [mm]	A - Weight lb [g]
25-100	1.97 [50.0]	2.27 [1030.0]
125-200	2.68 [68.1]	3.05 [1383.0]

Classic Series Pumps: 6010 Base

G 1" vacuum and exhaust ports are at opposite ends of the base. The pump is controlled via air-supply through the inlet port. Vacuum gauge, silencer, and full length t-slot are included.

Series	Capacity	Seal	Valve Options	Filter Option
ML	100	N	-6010	
E	25 (40)	E EPDM	(Blank) Standard	(Blank) Standard
L	50 (80)	N Nitrile	-NR Non-Return	-PFC Filter Combo
M	75 (120)	S Silicone	-LV No Valve	
ML	100 (160)	V Viton ²		
X	125 (200)			
	150 (240)			
	175 (280)			
	200 (320)			
	(X Series)			

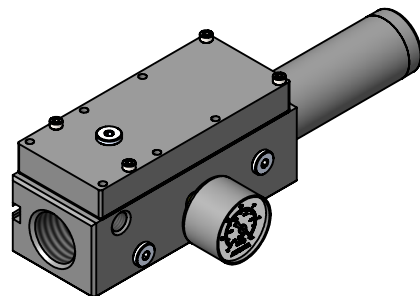
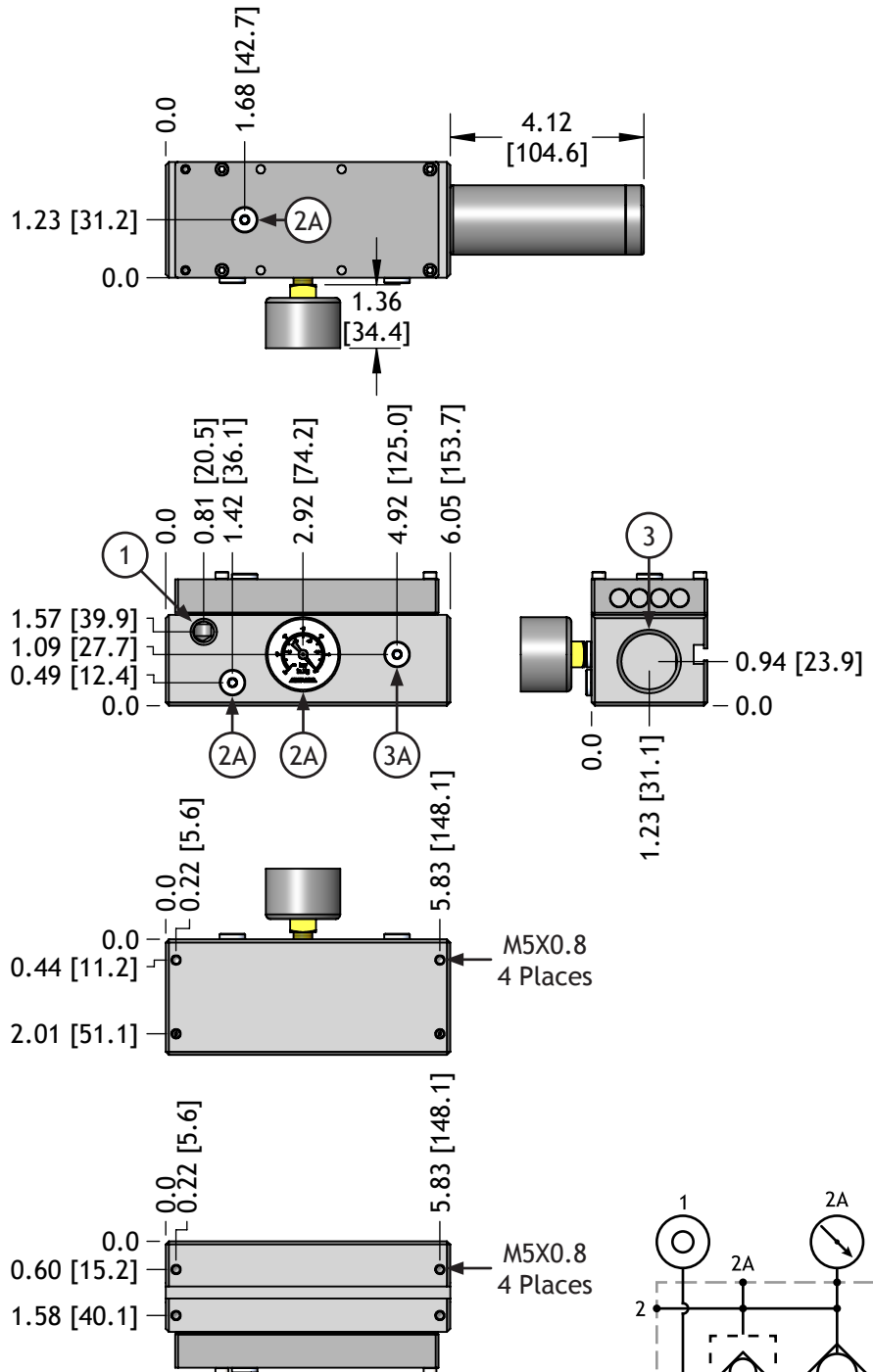

Code	Function	Ports
1	Air-Supply	1/4 NPSF
2	Vacuum	G 1
2A	Vacuum - Alternate	G 1/8 NPSF
3	Exhaust	G 3/4 NPSF
3A	Exhaust - Alternate	G 1/8 NPSF

Capacity	A in [mm]	A - Weight lb [g]
25-100	2.69 [68.3]	2.43 [1102.0]
125-200	3.40 [86.4]	3.02 [1370.0]

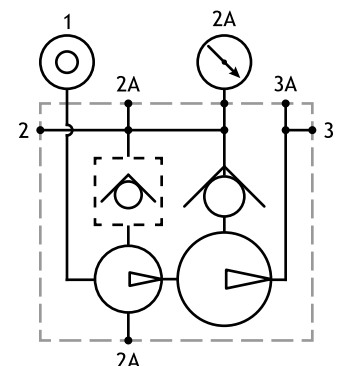

Classic Series Pumps: 6034 Base

3/4" vacuum and exhaust ports are at opposite ends of the base. The pump is controlled via air-supply through the inlet port. Vacuum gauge, silencer, and full length t-slot are included.

Series	Capacity	Seal	Ports	Valve Options	Filter Option
ML	100	N	-6034		
E	25 (40)	E EPDM	(Blank) NPTF Threads	(Blank) Standard	(Blank) Standard
L	50 (80)	N Nitrile	-G G Threads	-NR Non-Return	-PFC Filter Combo
M	75 (120)	S Silicone		-LV No Valve	
ML	100 (160)	V Viton ²			
X	125 (200)				
	150 (240)				
	175 (280)				
	200 (320)				

(X Series)

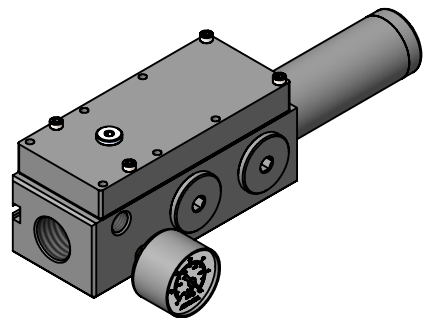
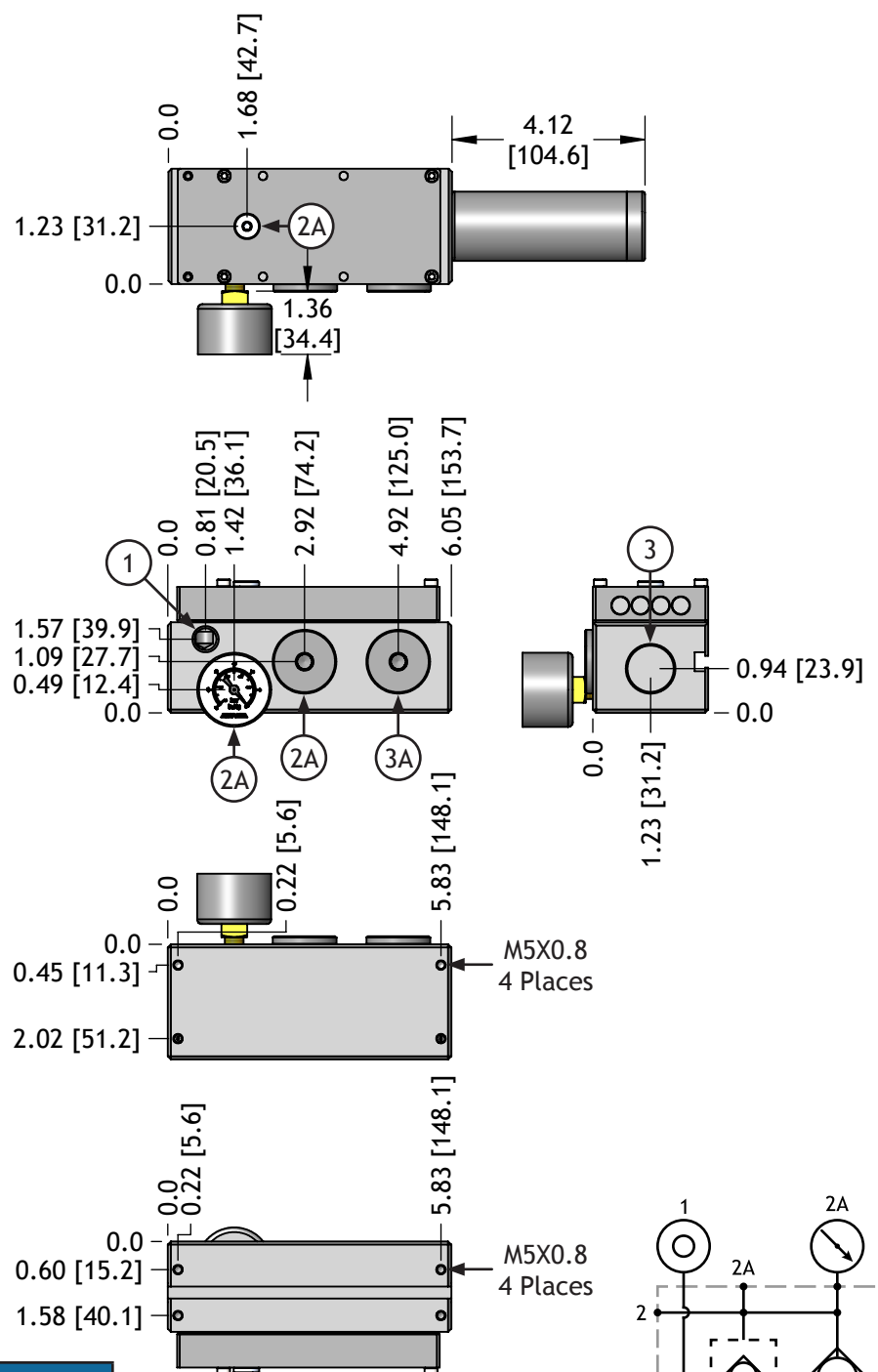

Code	Function	G	NPTF
1	Air-Supply	1/4 NPSF	G 1/4
2	Vacuum	G 3/4 NPSF	
2A	Vacuum - Alternate	G 1/8 NPSF	
3	Exhaust	G 3/4 NPSF	

Capacity	A in [mm]	A - Weight lb [g]
25-100	2.69 [68.3]	2.58 [1170.0]
125-200	3.40 [86.4]	3.17 [1438.0]

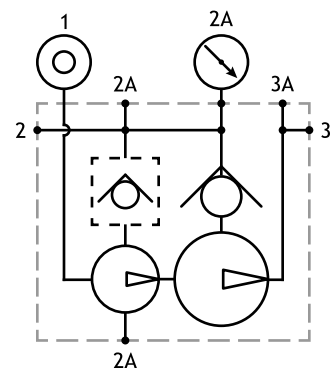

Classic Pump w/ Integrated Filter

Basic pump controlled via air supply through the pump base inlet port. This pump incorporates the bowl, gasket, and filter element of our t-style filters directly into the pump base eliminating the necessity of incorporating an external filter into the vacuum system.

Series	Capacity	Seal	Ports	Valve Options
ML	100	N		-IF
E	25 (40)	N	Nitrile (Blank) NPTF Threads	(Blank) Standard
L	50 (80)	V	Viton -G G Threads	-NR Non-Return
M	100 (160)			-LV No Valve
ML	(X Series)			
X				

Replacement Parts:

10503: Bowl

10514: Gasket

PPX35RE3: Filter Element (3 Pack)

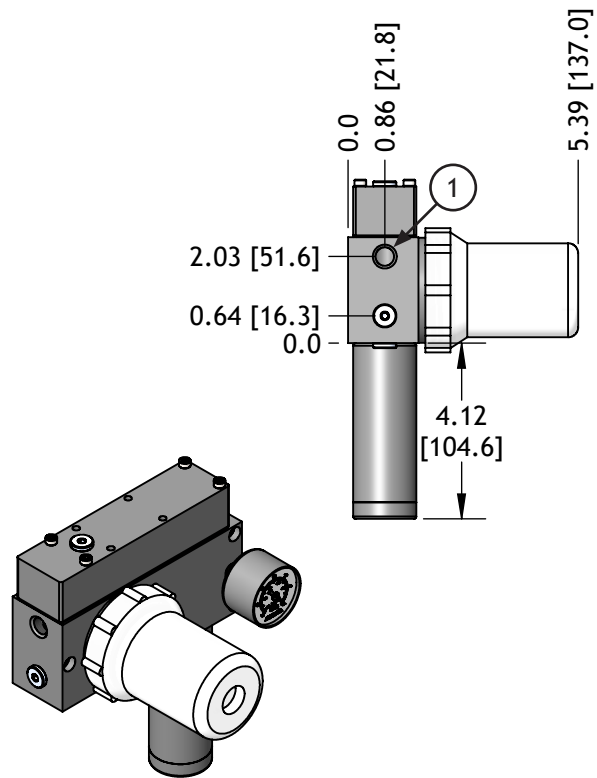
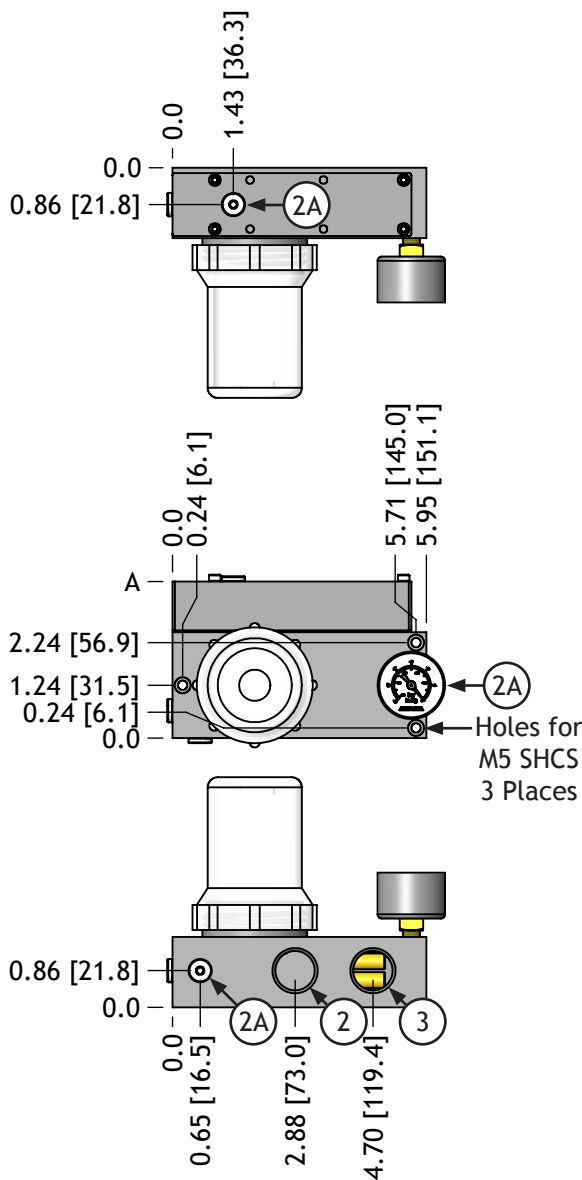

Capacity	A in [mm]	A - Weight lb [g]
25-50	3.24 [82.2]	3.09 [1400.5]
100	3.67 [93.3]	3.36 [1524.6]

Code	Function	NPTF	G
1	Air-Supply	1/4 NPTF	G 1/4
2	Vacuum	3/4 NPTF	G 3/4
2A	Vacuum - Alternate	G 1/8 NPSF	
3	Exhaust	3/4 NPTF	G 3/4

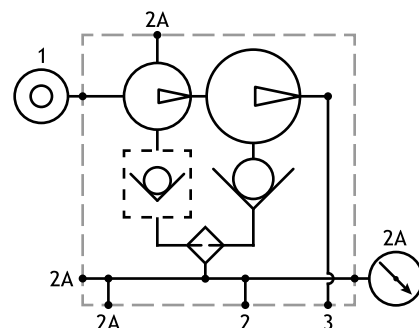

Classic Pump w/ Integrated Filter: Pilot Controlled Air-Supply

The pump base contains an integral, pilot-operated, 3-way air valve which controls vacuum on/off via pneumatic pilot signal. When the pilot signal is presented, the vacuum is turned on. When the pilot signal is exhausted, the pump turns off. This pump incorporates the bowl, gasket, and filter element of our t-style filters directly into the pump base eliminating the necessity of incorporating an external filter into the vacuum system.

Series	Capacity	Seal	Ports	Valve Options
ML	100	N	-IF-PS	(Blank) Standard
E	25 (40)	N	Nitrile (Blank) NPTF Threads	-NR Non-Return
L	50 (80)	V	Viton -G G Threads	-LV No Valve
M	100 (160)			
ML	(X Series)			
X				

Replacement Parts:

10503: Bowl

10514: Gasket

PPX35RE3: Filter Element (3 Pack)

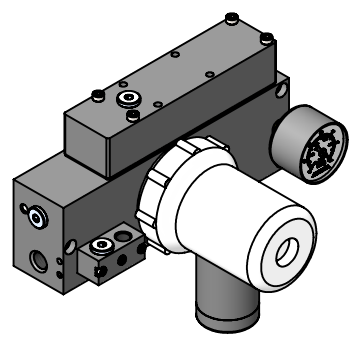
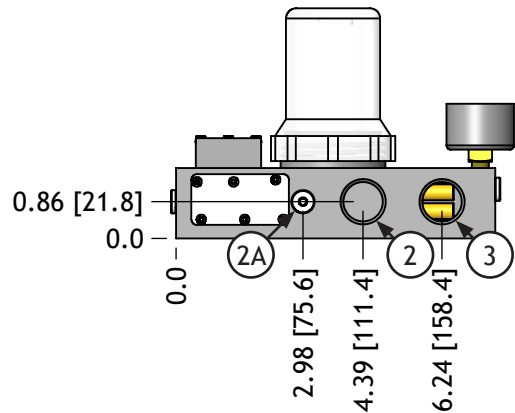
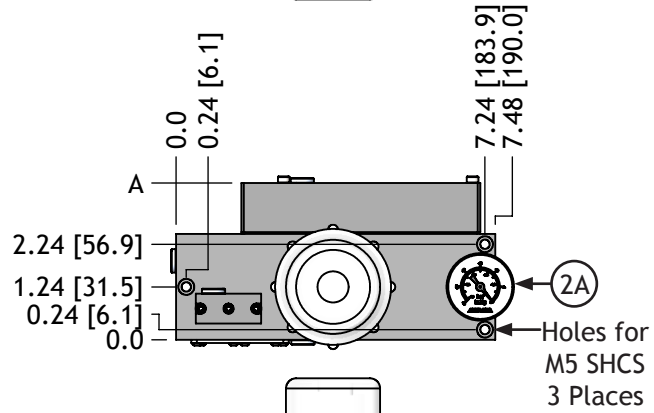
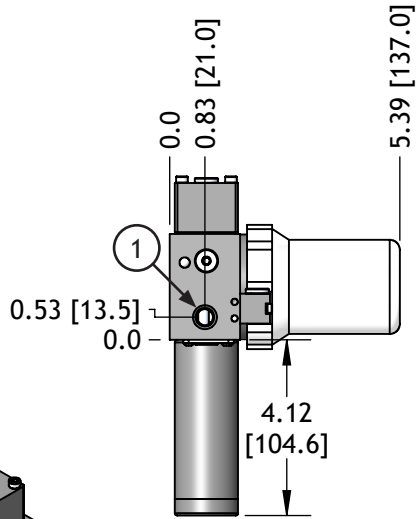
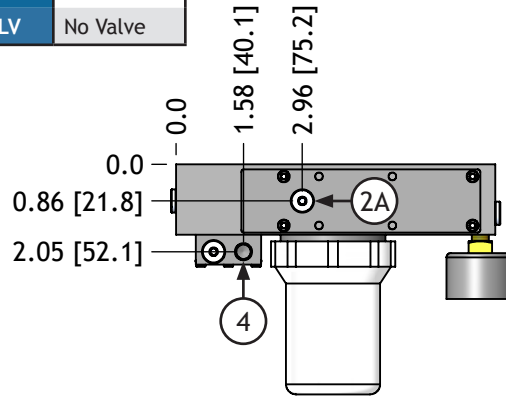

Capacity	A in [mm]	A - Weight lb [g]
25-50	3.24 [82.2]	3.78 [1712.9]
100	3.67 [93.3]	4.04 [1833.1]

Code	Function	NPTF	G
1	Air-Supply	1/4 NPTF	G 1/4
2	Vacuum	3/4 NPTF	G 3/4
2A	Vacuum - Alternate	G 1/8 NPSF	
3	Exhaust	3/4 NPTF	G 3/4
4	Pilot Signal - Air-Supply	G 1/8 NPSF	

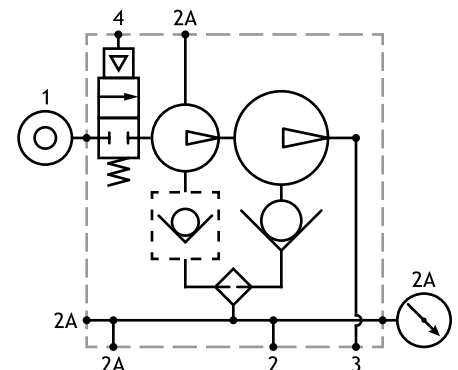

Classic Pump w/ Integrated Filter: Pilot Controlled Air-Supply & Blow-Off

The pump base contains two integral, pilot-operated, 3-way air valves which provide full pump control via two externally supplied pneumatic pilot signals. With a constant air-supply to the pump base, one pilot signal controls vacuum on/off while a second pilot signal controls blow-off air to dissipate vacuum for faster system cycle time. This pump incorporates the bowl, gasket, and filter element of our t-style filters directly into the pump base eliminating the necessity of incorporating an external filter into the vacuum system.

Series	Capacity	Seal	Ports	Valve Options
ML	100	N	-IF-PSB	
E	25 (40)	N	Nitrile (Blank) NPTF Threads	(Blank) Standard
L	50 (80)	V	Viton -G G Threads	-NR Non-Return
M	100 (160)			-LV No Valve
ML	(X Series)			
X				

Replacement Parts:
10503: Bowl
10514: Gasket
PPX35RE3: Filter Element (3 Pack)

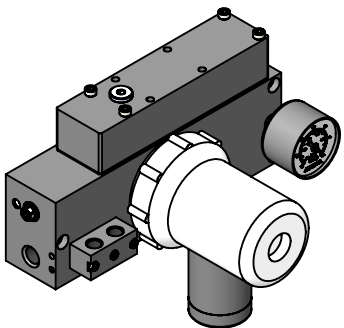
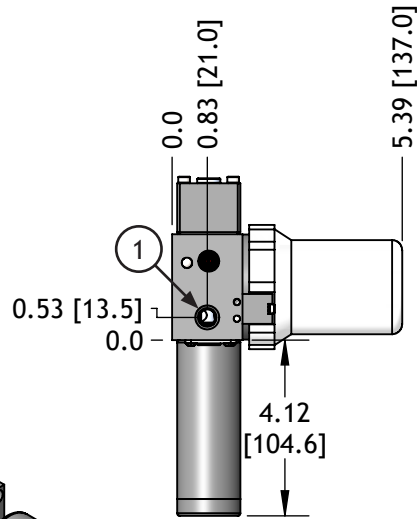
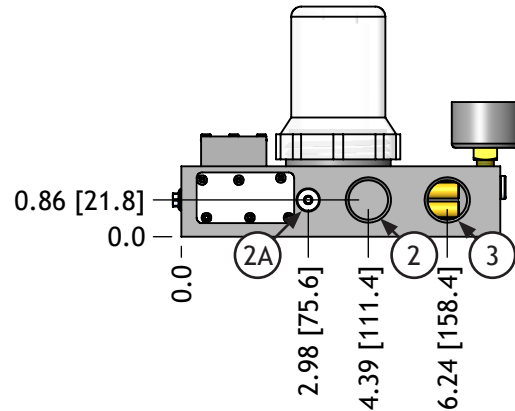
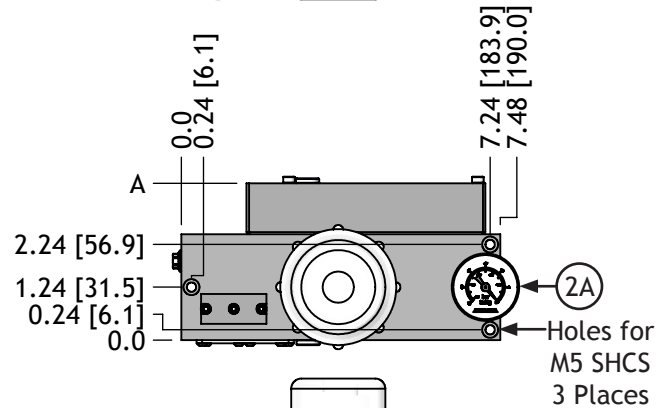
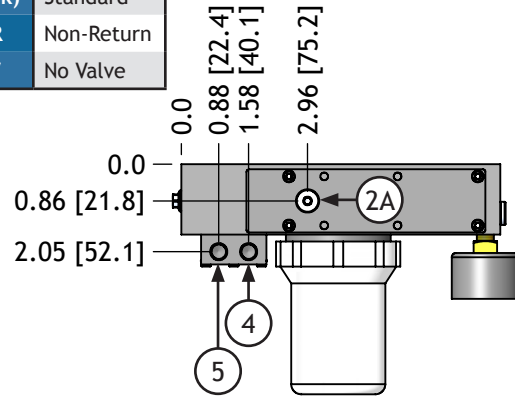

Capacity	A in [mm]	A - Weight lb [g]
25-50	3.24 [82.2]	3.78 [1712.4]
100	3.67 [93.3]	4.04 [1832.5]

Code	Function	NPTF	G
1	Air-Supply	1/4 NPTF	G 1/4
2	Vacuum	3/4 NPTF	G 3/4
2A	Vacuum - Alternate	G 1/8 NPSF	
3	Exhaust	3/4 NPTF	G 3/4
4	Pilot Signal - Air-Supply	G 1/8 NPSF	
5	Pilot Signal - Blow-Off	G 1/8 NPSF	

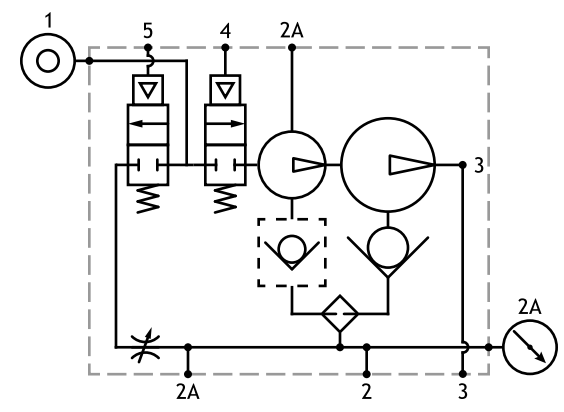

Classic Pump w/ Integrated Filter: Solenoid Controlled Air-Supply

The pump base contains an integral, pilot-operated, 3-way air valve which controls vacuum on/off via a solenoid valve. When the solenoid valve is energized, the vacuum pump turns on. When the solenoid valve is de-energized, the pump turns off. This pump incorporates the bowl, gasket, and filter element of our t-style filters directly into the pump base eliminating the necessity of incorporating an external filter into the vacuum system.

Series	Capacity	Seal	Ports	Solenoid Options	Valve Options
ML	100	N	-IF	-S24D	
E	25 (40)	N Nitrile (Blank)	NPTF Threads	-S24D 24 V DC, 2.3W	(Blank) Standard
L	50 (80)	V Viton -G	G Threads	-S110A 110V AC, 50 Hz	-NR Non-Return
M	100 (160)				-LV No Valve
ML	(X Series)				
X					

Replacement Parts:

- 10503: Bowl
- 10514: Gasket
- PPX35RE3: Filter Element (3 Pack)

Order DIN T-9 Molded Cords Separately:

- 923-2M01: Std. 2M
- 923-2M31: L.E.D. 0-50V, 2M
- 923-2M81: L.E.D. 70-250V, 2M

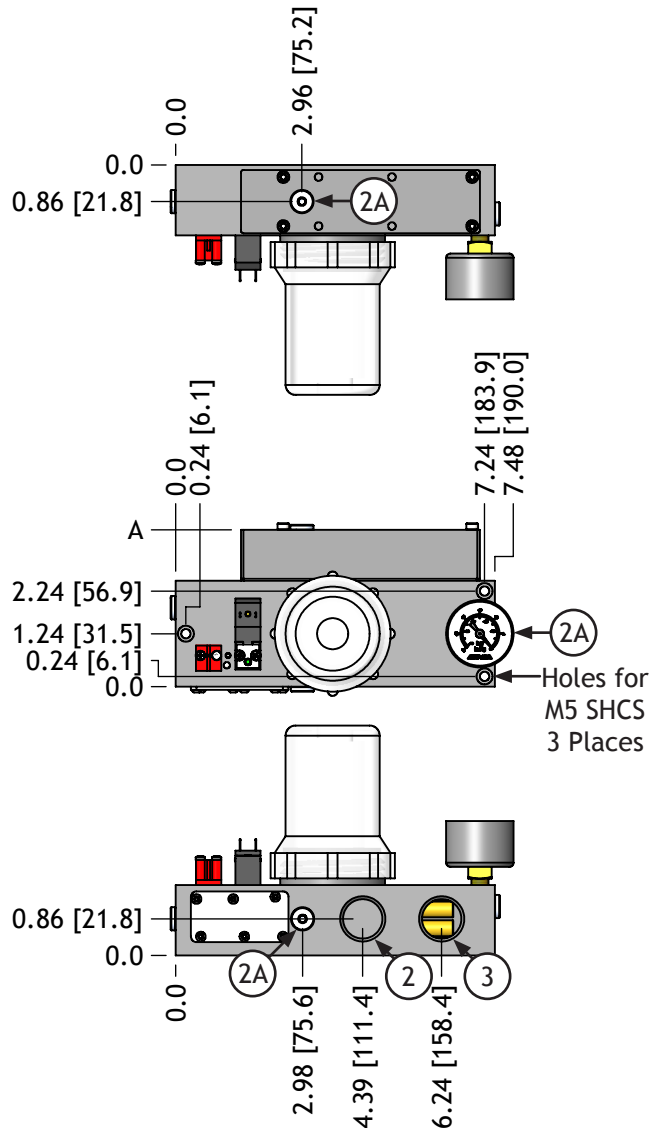
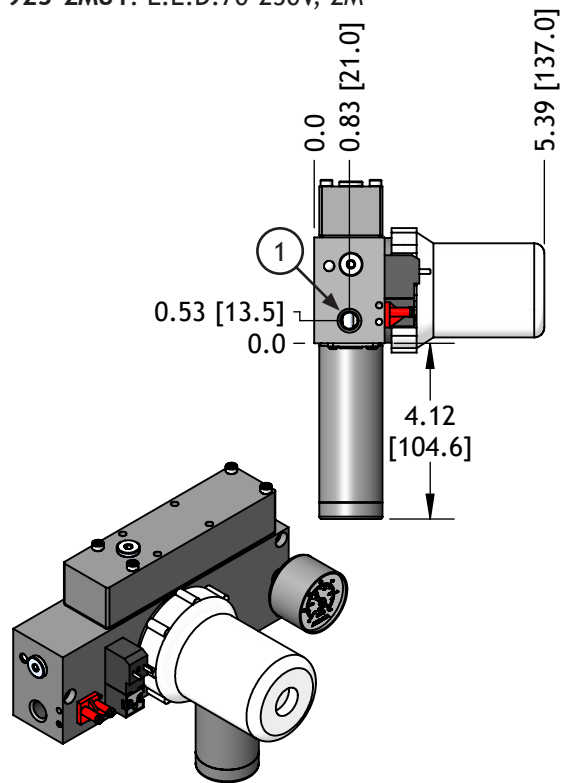

Capacity	A in [mm]	A - Weight lb [g]
25-50	3.24 [82.2]	3.73 [1692.0]
100	3.67 [93.3]	4.00 [1812.2]

Code	Function	NPTF	G
1	Air-Supply	1/4 NPTF	G 1/4
2	Vacuum	3/4 NPTF	G 3/4
2A	Vacuum - Alternate	G 1/8 NPSF	
3	Exhaust	3/4 NPTF	G 3/4

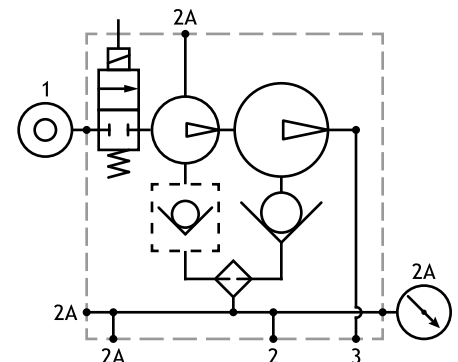

Classic Pump w/ Integrated Filter: Solenoid Controlled Air-Supply & Blow-Off

The pump base contains two integral, pilot-operated, 3-way air valves which provide full pump control via two solenoid valves. With a constant air-supply to the pump base, one solenoid valve controls vacuum on/off while a second solenoid valve controls blow-off air to dissipate vacuum for faster system cycle time. This pump incorporates the bowl, gasket, and filter element of our t-style filters directly into the pump base eliminating the necessity of incorporating an external filter into the vacuum system.

Series	Capacity	Seal	Ports	Solenoid Options	Valve Options
ML	100	N	-IF	-SB24D	
E	25 (40)	N Nitrile	(Blank) NPTF Threads	-SB24D 24 V DC, 2.3W	(Blank) Standard
L	50 (80)	V Viton	-G G Threads	-SB110A 110V AC, 50 Hz	-NR Non-Return
M	100 (160)				-LV No Valve
ML	(X Series)				
X					

Replacement Parts:

10503: Bowl

10514: Gasket

PPX35RE3: Filter Element (3 Pack)

Order DIN T-9 Molded Cords Separately:

923-2M01: Std. 2M

923-2M31: L.E.D. 0-50V, 2M

923-2M81: L.E.D.70-250V, 2M

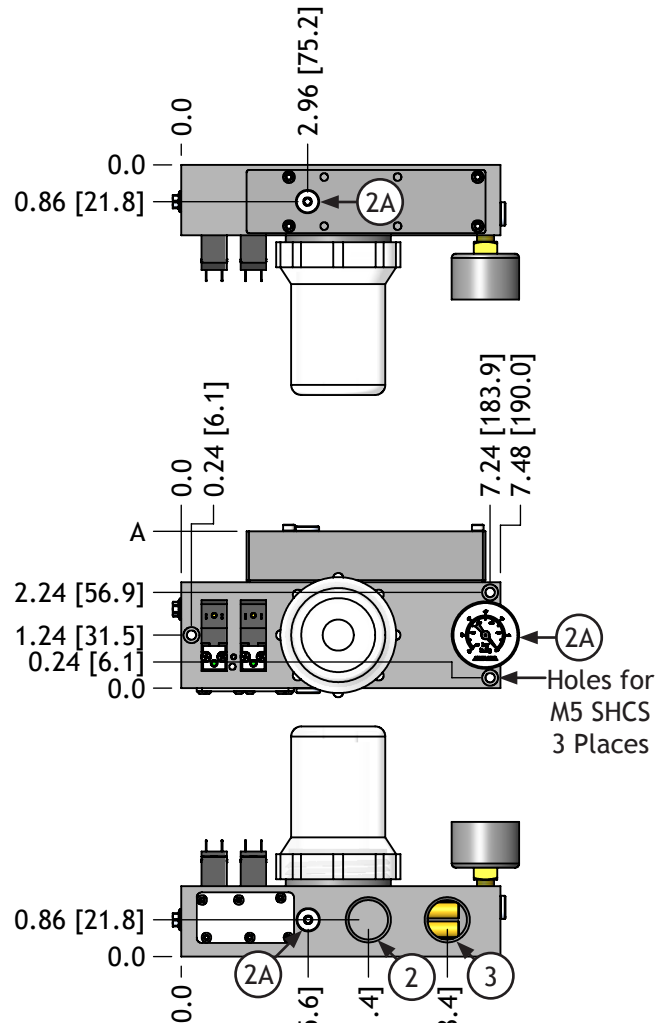
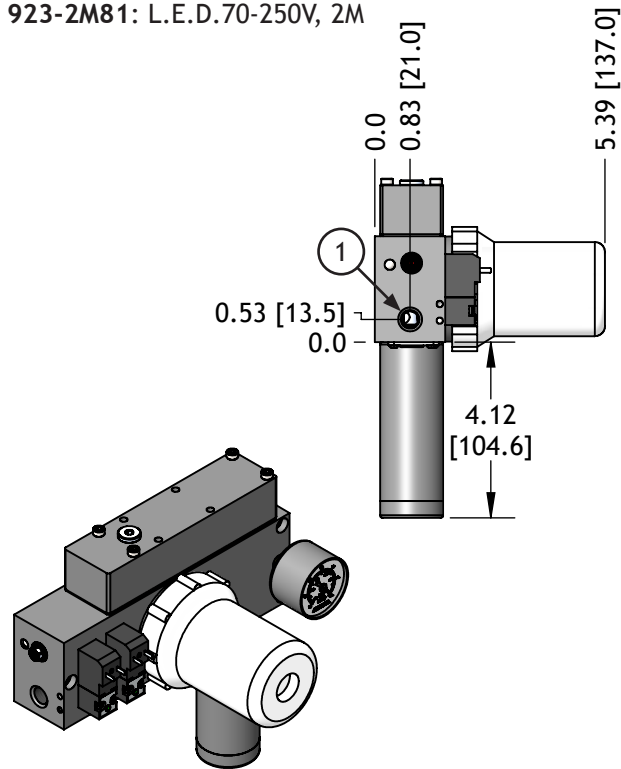

Capacity	A in [mm]	A - Weight lb [g]
25-50	3.24 [82.2]	3.76 [1703.7]
100	3.67 [93.3]	4.02 [1823.9]

Code	Function	NPTF	G
1	Air-Supply	1/4 NPTF	G 1/4
2	Vacuum	3/4 NPTF	G 3/4
2A	Vacuum - Alternate	G 1/8 NPSF	
3	Exhaust	3/4 NPTF	G 3/4

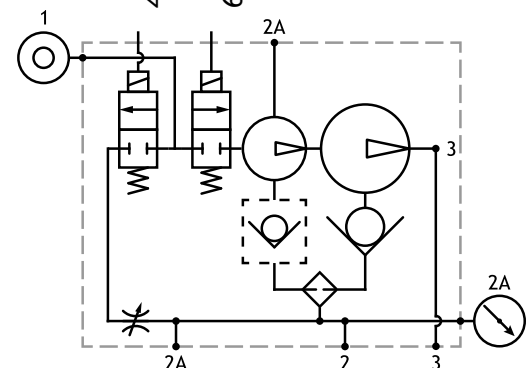

Classic Series Pumps: Mini-Classic

Basic pump controlled via air supply through the pump base inlet port.

Series	Capacity	Seal	Ports	Valve Options
ML	100	N	-12	
E	25 (40)	N Nitrile	(Blank) NPTF Threads	(Blank) Standard
L	50 (80)	V Viton	-G G Threads	-NR Non-Return
M	100 (160)			-LV No Valve
ML	(X Series)			
X				

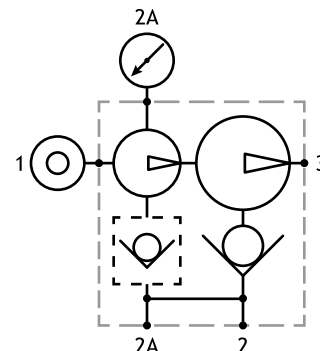
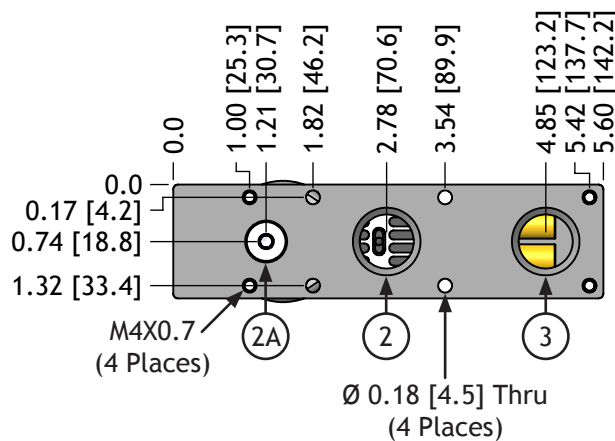
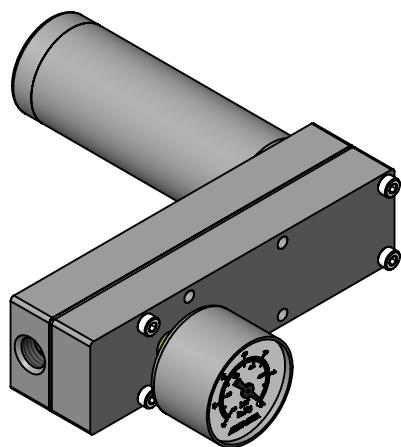
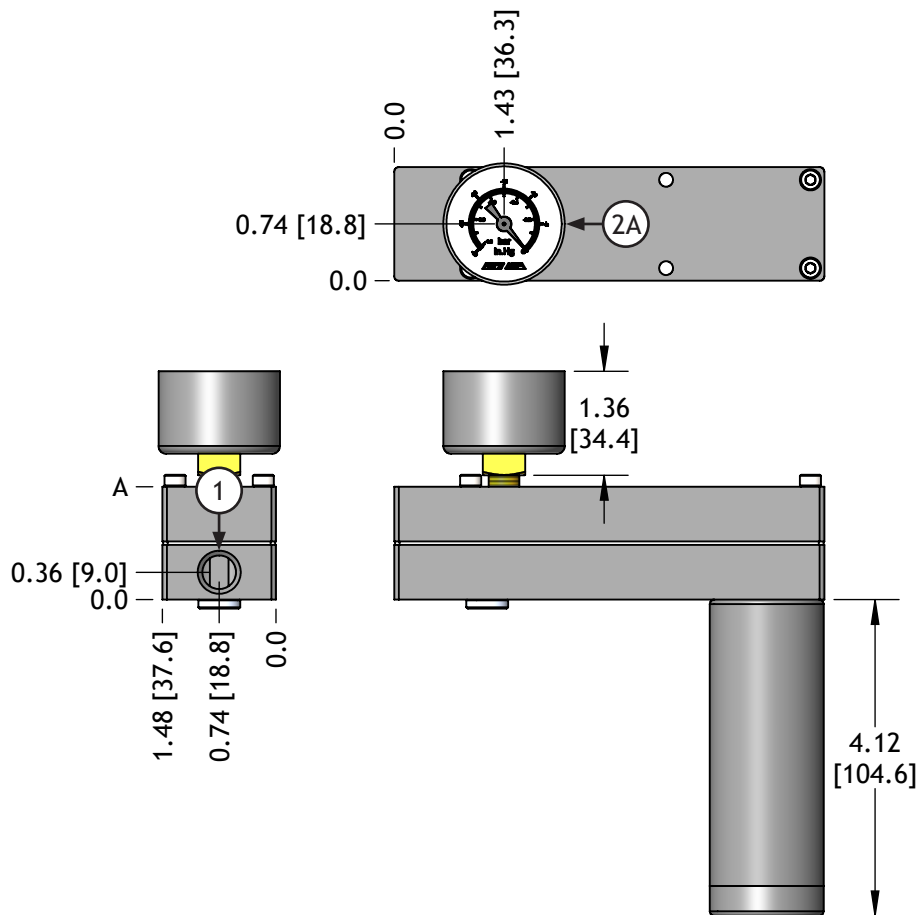

Code	Function	NPTF	G
1	Air-Supply	1/4 NPTF	G 1/4
2	Vacuum	1/2 NPTF	G 1/2
2A	Vacuum - Alternate	G 1/8 NPSF	
3	Exhaust	1/2 NPTF	G 1/2

Capacity	A in [mm]	A - Weight lb [g]
25-50	1.47 [37.3]	1.25 [565.7]
100	1.90 [48.3]	1.53 [693.7]

Classic Series Pumps: Dual-Base

Basic pump controlled via air supply through the pump base inlet port.

Series	Capacity	Seal	Valve Options
D ML	200	N	
E	200 (320)	E EPDM	(Blank) Standard
L	300 (480)	N Nitrile	-NR Non-Return
M	400 (640)	S Silicone	-LV No Valve
ML	(X Series)	V Viton ²	
X			

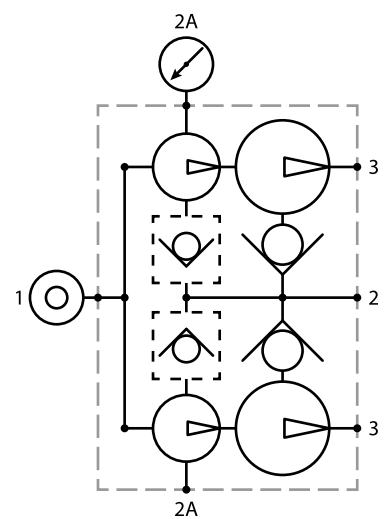
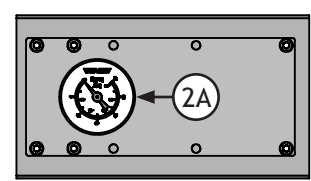
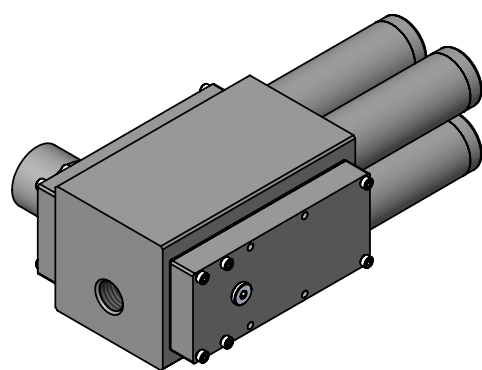
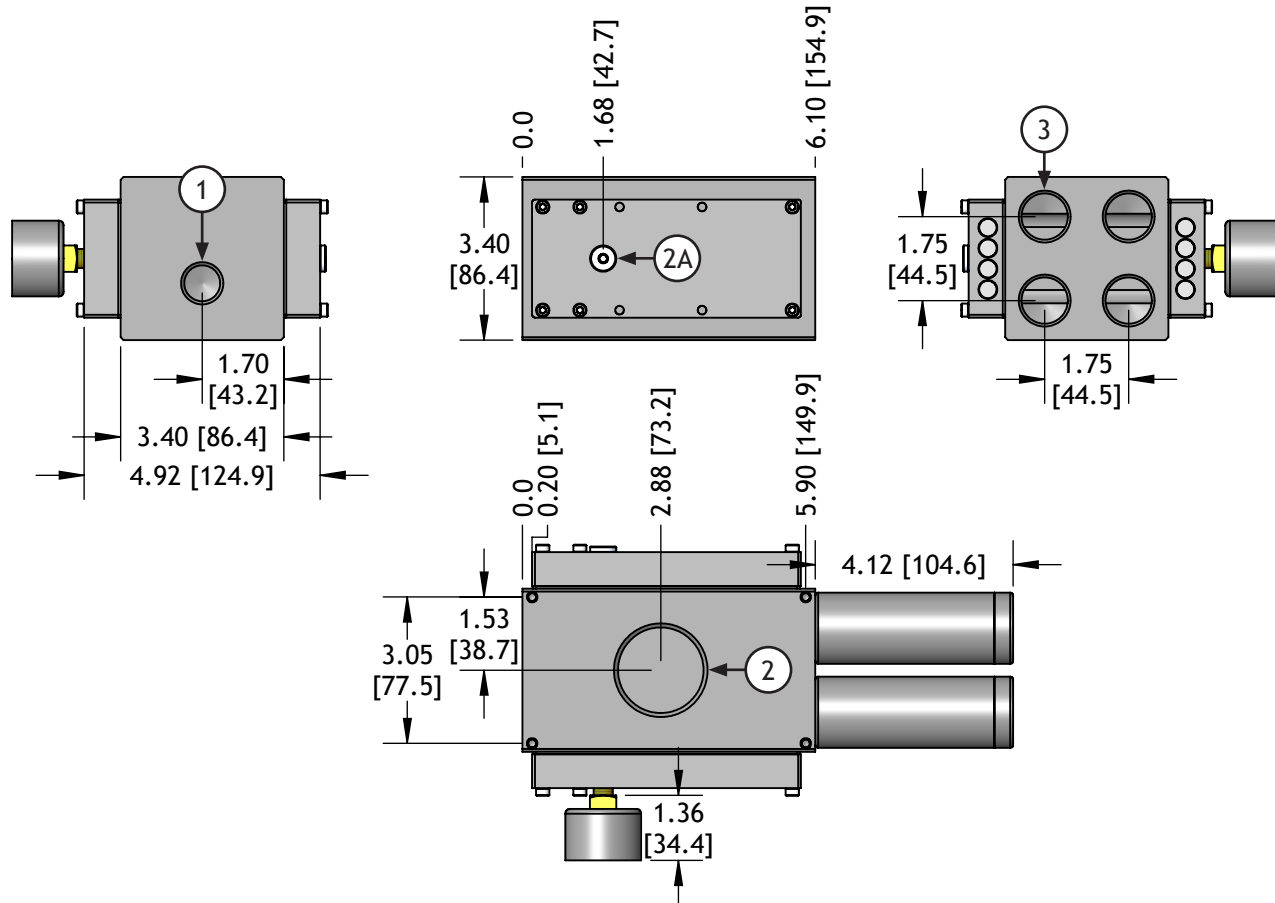

Code	Function	NPTF
1	Air-Supply	G 1/2 NPSF
2	Vacuum	G 1/2 NPSF
2A	Vacuum - Alternate	G 1/8 NPSF
3	Exhaust	G 3/4 NPSF

Capacity	A in [mm]	A - Weight lb [g]
200	4.92 [124.9]	6.94 [3146.8]
300	5.63 [142.9]	7.58 [3436.3]
400	6.34 [160.9]	8.21 [3752.9]

Classic Series Pumps: Triple-Base

Basic pump controlled via air supply through the pump base inlet port.

Series	Capacity	Seal	Ports	Valve Options	Exhaust Option
T	ML	300	N		
E	300 (480)	E	EPDM	(Blank) NPTF Threads	(Blank) Standard
L	400 (640)	N	Nitrile	-G G Threads	-NR Non-Return
M	500 (800)	S	Silicone	-LV No Valve	
ML	600 (960)	V	Viton ²		
X	(X Series)				

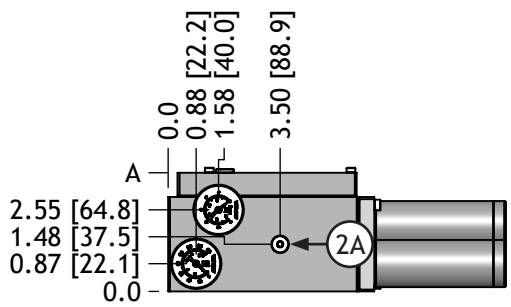
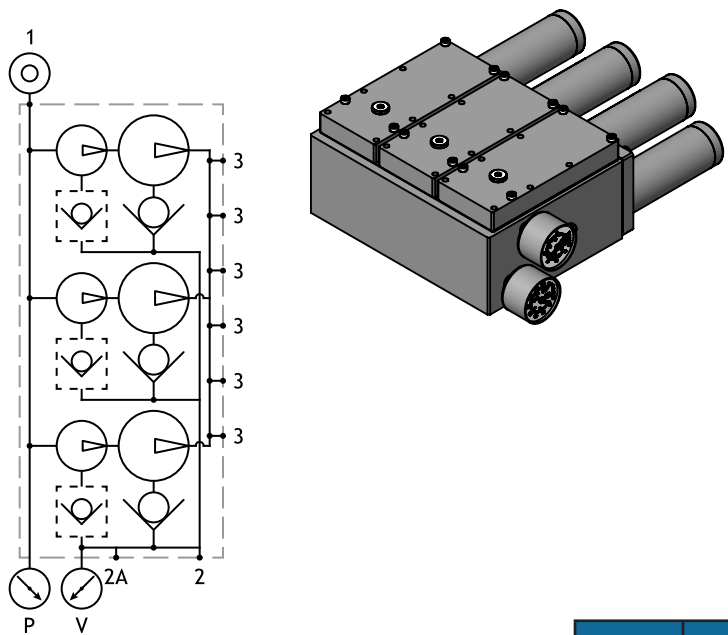
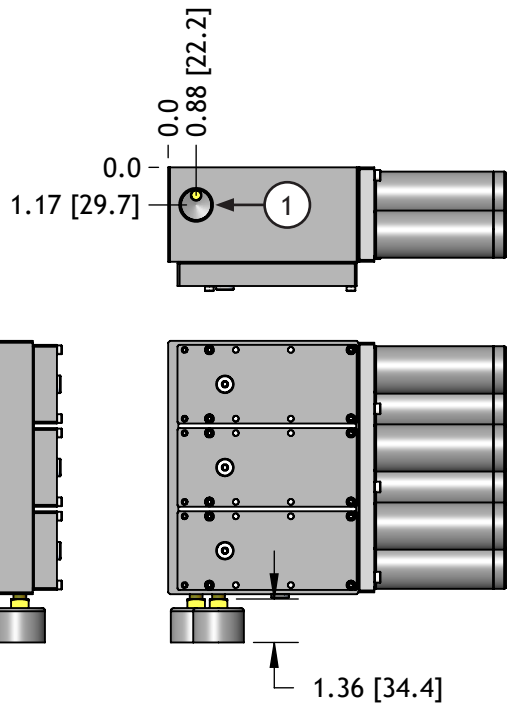
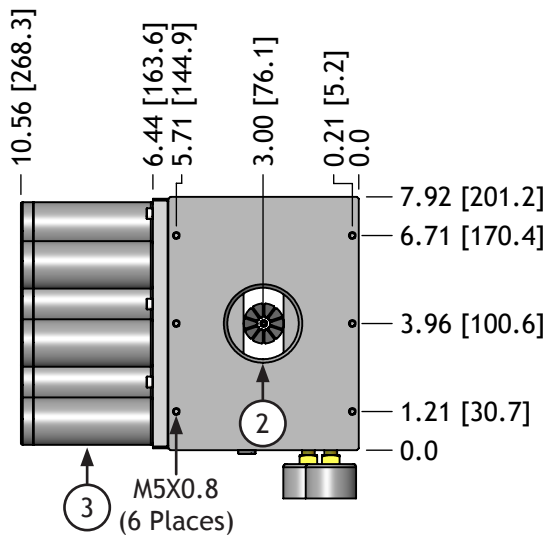

Code	Function	NPTF	G	Capacity	A in [mm]	A - Weight lb [g]
1	Air-Supply	3/4 NPTF	G 3/4	300	3.71 [94.2]	12.68 [5749.8]
2	Vacuum	2 NPTF	G 2	400	4.42 [112.2]	13.31 [6039.3]
2A	Vacuum - Alternate	G 1/8 NPSF		500	4.42 [112.2]	13.95 [6328.8]
3	Exhaust	3/4 NPTF	G 3/4	600	4.42 [112.2]	14.59 [6618.3]

Classic Series Pumps: Quad-Base

Basic pump controlled via air supply through the pump base inlet port.

Series	Capacity	Seal	Valve Options	Exhaust Option
Q ML	400	N		
E	400 (640)	E EPDM	(Blank) Standard	(Blank) Standard
L	500 (800)	N Nitrile	-NR Non-Return	-CE Captured
M	600 (960)	S Silicone	-LV No Valve	
ML	700 (1120)	V Viton ²		
X	800 (1280)			

(X Series)

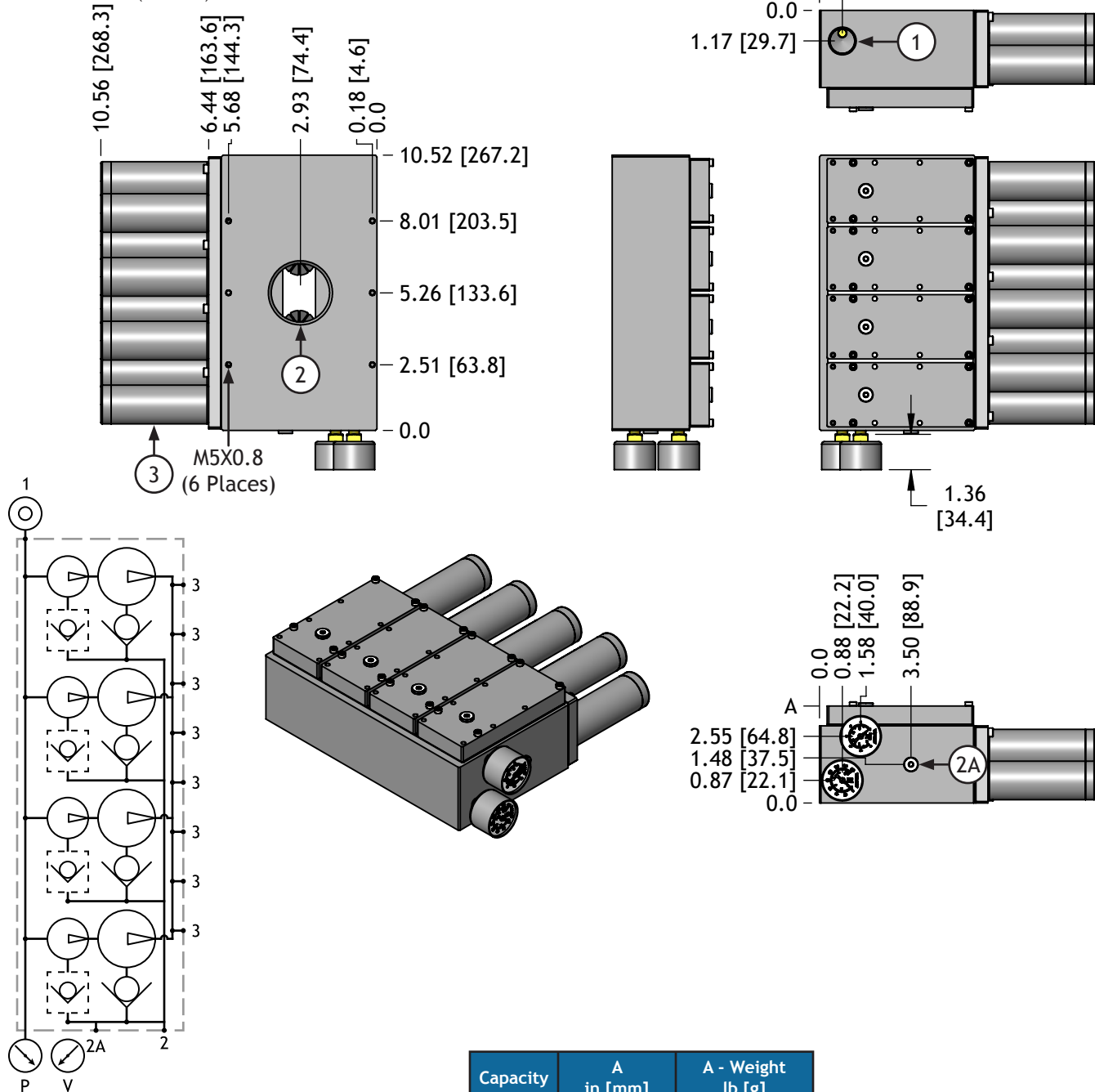

Code	Function	NPTF	G
1	Air-Supply	3/4 NPTF	G 3/4
2	Vacuum	2 NPTF	G 2
2A	Vacuum - Alternate	G 1/8 NPSF	
3	Exhaust	3/4 NPTF	G 3/4

Capacity	A in [mm]	A - Weight lb [g]
400	3.71 [94.2]	16.78 [7610.0]
500	4.42 [112.2]	17.42 [7899.6]
600	4.42 [112.2]	18.05 [8189.1]
700	4.42 [112.2]	18.69 [8478.6]
800	4.42 [112.2]	19.33 [8768.1]

Classic Series Pumps: Captured Exhaust Option

To use the Captured Exhaust Option, use 3.00" (75 mm) inner diameter hose.

Triple-Base

Subtract Weight: 0.97 lb [438.5 g]

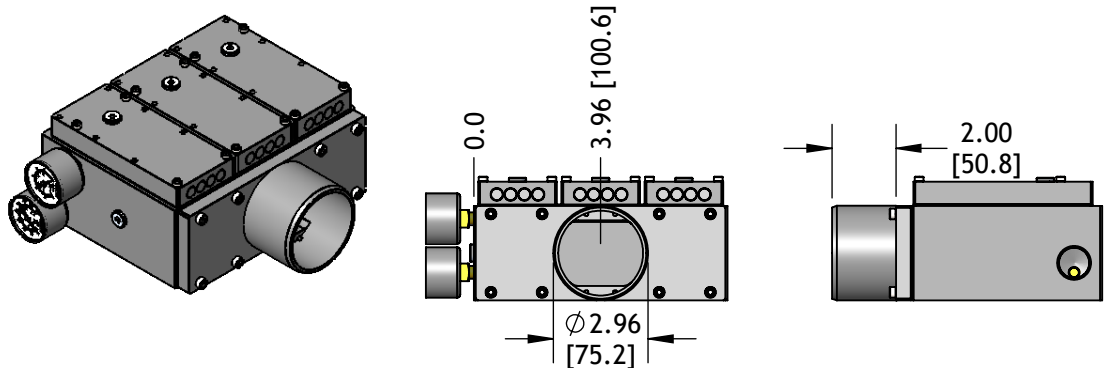

Quad-Base

Subtract Weight: 1.22 lb [553.0 g]

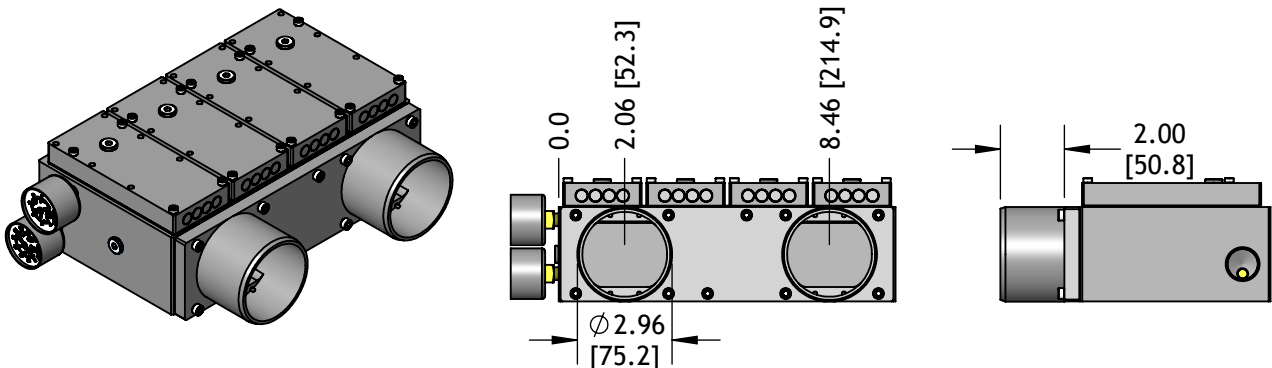

Classic Series Pumps: Performance

Series Selection

Code	Description	Max Vacuum inHG [-kPa]	Supply Pressure psi [bar]
A	Ultra-High Flow	27.0 [91.4]	87 [6]
E	Ultra-High Flow	26.7 [90.4]	87 [6]
L	High Flow	22.8 [77.2]	87 [6]
M	Low Pressure	27.1 [91.8]	49 [3.4]
ML	Multi-Characteristic	27.5 [93.1]	58-87 [4-6]
X	High Vacuum	28.3 [95.8]	87 [6]

Seal Material

Code	Description	Working Temperature	Color
E	Ethyl Propylene (E.P.D.M.)	-4°F to 230°F -20°C to 110°C	Black
N	Nitrile (Buna-N)	-4°F to 230°F -20°C to 110°C	Black
S	Silicone	-100°F to 400°F -70°C to 205°C	Orange
V ¹	Fluorocarbon (Viton ²)	-40°F to 450°F 4°C to 230°C	Gray

¹For operating temperatures above 180°F [82.2°C]. The pump will be assembled using high-temperature sealant, metal end plugs, and will be supplied without exhaust silencer and vacuum gauge. Available for basic pump style only.

²Viton is a registered trademark of Du Pont Dow Elastomers.

All performance data presented is a representation of production pumps but is not a guarantee due to variations in local barometric pressure and of mass produced components.

Classic Series Pumps: Performance

Vacuum Flow - SCFM

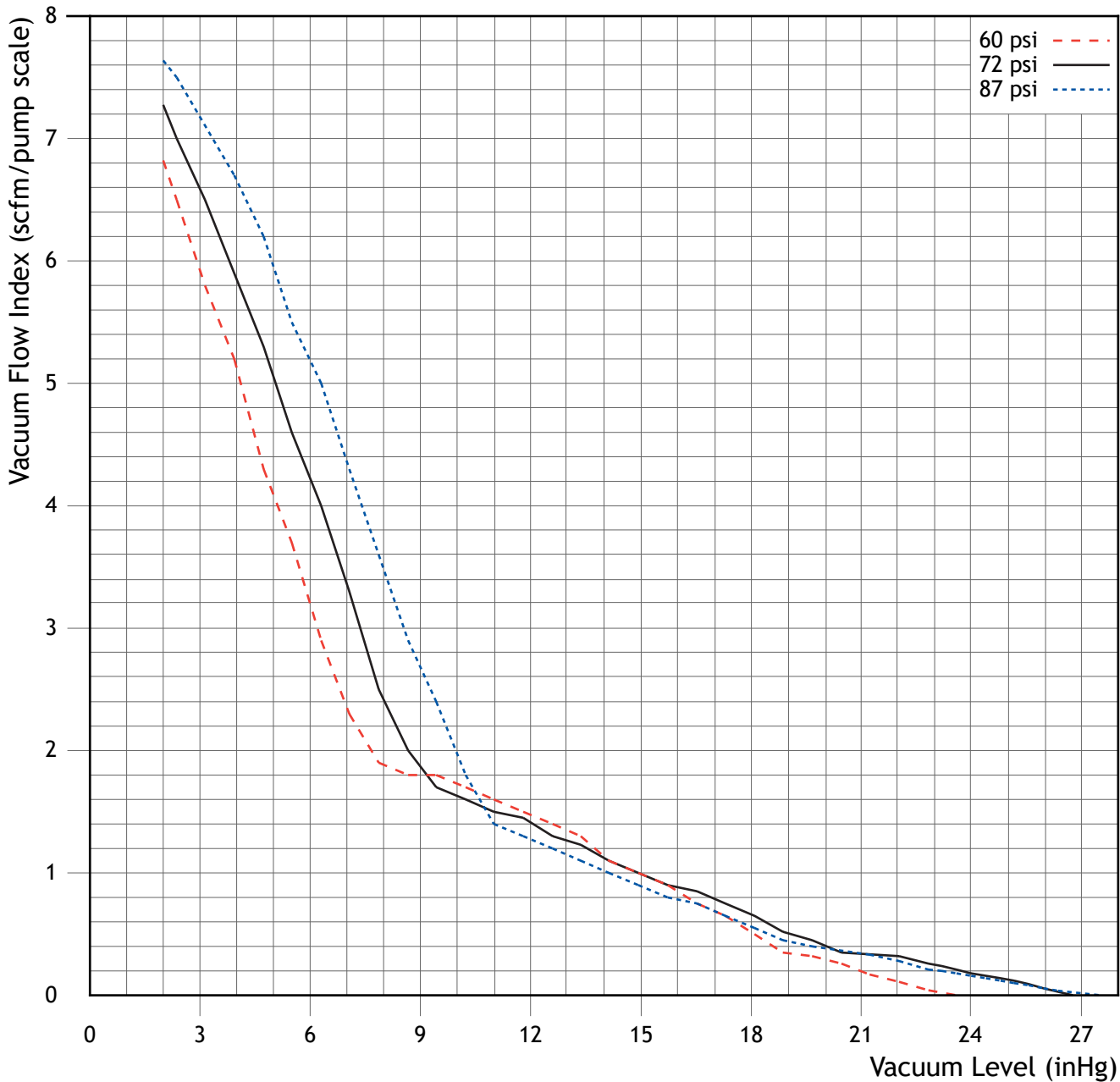

Capacity	25	50	75	100	125	150	175	200	300	400	500	600	700	800	900	1000	1100	1200
Scale	1	2	3	4	5	6	7	8	12	16	20	24	28	32	36	40	44	48

SCFM X 28.32 = nl / m

Evacuation Time - Sec / 1,000 in³

Air Supply PSI	Air Consum SCFM	Max Vacuum inHg	Seconds to Evacuate 1,000 in ³ to Vacuum Level								
			3 inHg	6 inHg	9 inHg	12 inHg	15 inHg	18 inHg	21 inHg	24 inHg	26 inHg
60	3.0	23.6	0.39	1.1	2.9	4.3	7.5	12.9	29.3	-	-
72	3.5	26.8	0.36	0.93	1.9	3.8	6.6	11.4	20.2	39.5	70
87	4.0	27.5	0.35	0.87	1.7	3.3	5.9	10.2	18.4	35.8	64

sec / 1,000 cu in X 0.61 = sec / l

All performance data presented is a representation of production pumps but is not a guarantee due to variations in local barometric pressure and of mass produced components.

Classic Series Pumps: Performance

Vacuum Flow - SCFM

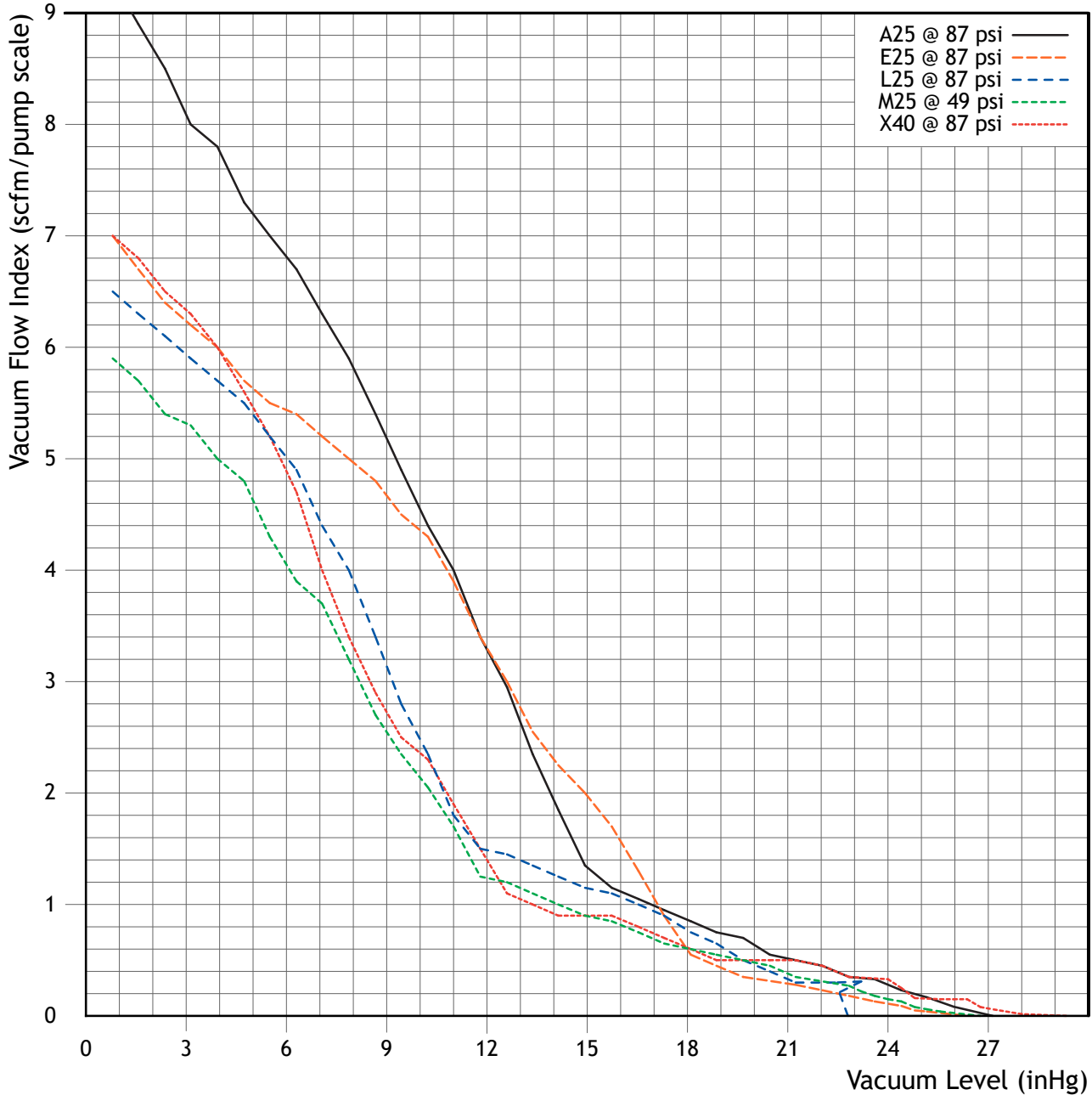

Capacity	25	50	75	100	125	150	175	200	300	400	500	600	700	800	900	1000	1100	1200
Scale	1	2	3	4	5	6	7	8	12	16	20	24	28	32	36	40	44	48

SCFM X 28.32 = nl / m

Evacuation Time - Sec / 1,000 in³

Pump Series	Air Supply PSI	Air Consum SCFM	Max Vacuum inHg	Seconds to Evacuate 1,000 in ³ to Vacuum Level								
				3 inHg	6 inHg	9 inHg	12 inHg	15 inHg	18 inHg	21 inHg	24 inHg	26 inHg
A	87	6.8	27.1	0.31	0.75	1.4	2.5	4.3	7.4	13.2	25.6	45
E	87	6.8	26.7	0.4	0.99	1.8	3.0	5.09	8.7	15.6	30.6	56
L	87	4.0	22.8	0.44	1.04	1.9	3.6	6.34	10.8	19.3	-	-
M	49	4.3	27.1	0.48	1.18	2.3	4.2	7.36	12.7	22.5	43.7	77
X	87	5.4	28.3	0.4	1.0	2.0	3.6	6.4	11.1	19.6	38	67

sec / 1,000 in³ X 0.61 = sec / l

All performance data presented is a representation of production pumps but is not a guarantee due to variations in local barometric pressure and of mass produced components.

Classic Series Pumps: Performance

Vacuum Flow - SCFM

Model	Air Supply PSI	Air Consum SCFM	Max Vacuum inHg	SCFM at Vacuum Level (inHg)									
				3 inHg	6 inHg	9 inHg	12 inHg	15 inHg	18 inHg	21 inHg	24 inHg	26 inHg	27 inHg
E25	87	6.8	26.7	6.24	5.44	4.67	3.3	1.98	0.6	0.29	0.11	0.012	-
E50	87	13.6	26.7	12.5	10.9	9.34	6.6	3.96	1.2	0.58	0.22	0.024	-
E75	87	20.4	26.7	18.7	16.3	14.0	9.9	5.94	1.8	0.87	0.33	0.036	-
E100	87	27.2	26.7	25.0	21.8	18.7	13.2	7.92	2.4	1.16	0.44	0.048	-
E125	87	34.0	26.7	31.2	27.2	23.4	16.5	9.9	3.0	1.45	0.55	0.06	-
E150	87	40.8	26.7	37.4	32.6	28.0	19.8	11.9	3.6	1.74	0.66	0.072	-
E175	87	47.6	26.7	43.7	38.1	32.7	23.1	13.9	4.2	2.03	0.77	0.084	-
E200	87	54.4	26.7	49.9	43.5	37.4	26.4	15.8	4.8	2.32	0.88	0.096	-
E300	87	81.6	26.7	74.9	65.3	56.0	39.6	23.8	7.2	3.48	1.32	0.14	-
L25	87	4.0	22.8	5.57	4.63	3.15	1.8	1.37	1.06	0.74	-	-	-
L50	87	8.0	22.8	11.1	9.26	6.30	3.6	2.74	2.12	1.48	-	-	-
L75	87	12.0	22.8	16.7	13.9	9.45	5.4	4.11	3.18	2.22	-	-	-
L100	87	16.0	22.8	22.3	18.5	12.6	7.2	5.48	4.24	2.96	-	-	-
L125	87	20.0	22.8	27.9	23.2	15.8	9.0	6.85	5.3	3.7	-	-	-
L150	87	24.0	22.8	33.4	27.8	18.9	10.8	8.22	6.36	4.44	-	-	-
L175	87	28.0	22.8	39.0	32.4	22.0	12.6	9.59	7.42	5.18	-	-	-
L200	87	32.0	22.8	44.6	37.0	25.2	14.4	11.0	8.48	5.92	-	-	-
L300	87	48.0	22.8	66.8	55.6	37.8	21.6	16.4	12.7	8.88	-	-	-
M25	49	4.3	27.1	5.32	4.05	2.55	1.24	0.9	0.61	0.38	0.15	0.03	-
M50	49	8.6	27.1	10.6	8.1	5.1	2.48	1.8	1.22	0.76	0.3	0.06	-
M75	49	12.9	27.1	16.0	12.2	7.65	3.72	2.7	1.83	1.14	0.45	0.09	-
M100	49	17.2	27.1	21.3	16.2	10.2	4.96	3.6	2.44	1.52	0.6	0.12	-
M125	49	21.5	27.1	26.6	20.3	12.8	6.2	4.5	3.05	1.9	0.75	0.15	-
M150	49	25.8	27.1	31.9	24.3	15.3	7.44	5.4	3.66	2.28	0.9	0.18	-
M175	49	30.1	27.1	37.2	28.4	17.9	8.68	6.3	4.27	2.66	1.05	0.21	-
M200	49	34.4	27.1	42.6	32.4	20.4	9.92	7.2	4.88	3.04	1.2	0.24	-
M300	49	51.6	27.1	63.8	48.6	30.6	14.9	9.72	7.32	4.56	1.8	0.36	-
ML25	87	4.0	27.5	7.17	5.12	2.91	1.27	0.84	0.51	0.34	0.16	0.06	0.017
ML50	87	8.0	27.5	14.3	10.2	5.82	2.54	1.68	1.02	0.68	0.32	0.12	0.034
ML75	87	12.0	27.5	21.5	15.4	8.73	3.81	2.52	1.53	1.02	0.48	0.18	0.051
ML100	87	16.0	27.5	28.7	20.5	11.6	5.08	3.36	2.04	1.36	0.64	0.24	0.068
ML125	87	20.0	27.5	35.9	25.6	14.6	6.35	4.2	2.55	1.7	0.8	0.3	0.085
ML150	87	24.0	27.5	43.0	30.7	17.5	7.62	5.04	3.06	2.04	0.96	0.36	0.102
ML175	87	28.0	27.5	50.2	35.8	20.4	8.89	5.88	3.57	2.38	1.12	0.42	0.119
ML200	87	32.0	27.5	57.4	41.0	23.3	10.2	6.72	4.08	2.72	1.28	0.48	0.136
ML300	87	48.0	27.5	86.0	61.4	34.9	15.2	10.1	6.12	4.08	1.92	0.72	0.2
X40	87	5.4	28.3	6.33	4.89	2.73	1.4	0.9	0.61	0.5	0.33	0.15	0.067
X80	87	10.8	28.3	12.7	9.78	5.46	2.8	1.8	1.22	1.0	0.66	0.3	0.134
X120	87	16.2	28.3	19.0	14.7	8.19	4.2	2.7	1.83	1.5	0.99	0.45	0.201
X160	87	21.6	28.3	25.3	19.6	10.9	5.6	3.6	2.44	2.0	1.32	0.6	0.268
X200	87	27.0	28.3	31.7	24.5	13.7	7.0	4.5	3.05	2.5	1.65	0.75	0.335
X240	87	32.4	28.3	38.0	29.3	16.4	8.4	5.4	3.66	3.0	1.98	0.9	0.402
X280	87	37.8	28.3	44.3	34.2	19.1	9.8	6.3	4.27	3.5	2.31	1.05	0.469
X320	87	43.2	28.3	50.6	39.1	21.8	11.2	7.2	4.88	4.0	2.64	1.2	0.536
X480	87	64.8	28.3	76	58.7	32.8	16.8	10.8	7.32	6.0	3.96	1.8	0.8

SCFM X 28.32 = nl / m

All performance data presented is a representation of production pumps but is not a guarantee due to variations in local barometric pressure and of mass produced components.

Classic Series Pumps: Performance

Vacuum Flow - SCFM

Model	Air Supply PSI	Air Consum SCFM	Max Vacuum inHg	SCFM at Vacuum Level (inHg)									
				3 inHg	6 inHg	9 inHg	12 inHg	15 inHg	18 inHg	21 inHg	24 inHg	26 inHg	27 inHg
E400	87	109	26.7	99.8	87	74.7	52.8	31.7	9.6	4.64	1.76	0.19	-
E500	87	136	26.7	125	109	93.4	66	39.6	12	5.8	2.2	0.24	-
E600	87	163	26.7	150	131	112	79.2	47.5	14.4	6.96	2.6	0.29	-
E700	87	190	26.7	175	152	131	92.4	55.4	16.8	8.12	3.08	0.34	-
E800	87	218	26.7	200	174	149	106	63.4	19.2	9.28	3.52	0.38	-
E900	87	245	26.7	225	196	168	119	71.3	21.6	10.4	3.96	0.43	-
E1000	87	272	26.7	250	218	187	132	79.2	24	11.6	4.4	0.48	-
E1100	87	299	26.7	275	240	205	145	87.1	26.4	12.8	4.84	0.53	-
E1200	87	326	26.7	300	262	224	158	95	28.8	13.9	5.3	0.58	-
L400	87	64	22.8	89.1	74.1	50.4	28.8	21.9	17	11.8	-	-	-
L500	87	80	22.8	111	92.6	63	36	27.4	21.2	14.8	-	-	-
L600	87	96	22.8	134	111	75.6	43.2	32.9	25.4	17.8	-	-	-
L700	87	112	22.8	156	130	88.2	50.4	38.4	29.7	20.7	-	-	-
L800	87	128	22.8	178	148	101	57.6	43.8	33.9	23.7	-	-	-
L900	87	144	22.8	201	167	113	64.8	49.3	38.2	26.6	-	-	-
L1000	87	160	22.8	223	185	126	72	54.8	42.4	29.6	-	-	-
L1100	87	176	22.8	245	204	139	79.2	60.3	46.6	32.6	-	-	-
L1200	87	192	22.8	267	222	151	86.4	65.8	50.9	35.5	-	-	-
M400	49	68.8	27.1	85.1	64.8	40.8	19.8	14.4	9.76	6.08	2.4	0.48	-
M500	49	86	27.1	106	81	51	24.8	18	12.2	7.6	3	0.6	-
M600	49	103	27.1	128	97.2	61.2	29.8	21.6	14.6	9.12	3.6	0.72	-
M700	49	120	27.1	149	113	71.4	34.7	25.2	17.1	10.6	4.2	0.84	-
M800	49	138	27.1	170	130	81.6	39.7	28.8	19.5	12.2	4.8	0.96	-
M900	49	155	27.1	192	146	91.8	44.6	32.4	22.0	13.7	5.4	1.08	-
M1000	49	172	27.1	213	162	102	49.6	36	24.4	15.2	6	1.2	-
M1100	49	189	27.1	234	178	112	54.6	39.6	26.8	16.7	6.6	1.32	-
M1200	49	206	27.1	255	194	122	59.5	43.2	29.3	18.2	7.2	1.44	-
ML400	87	64	27.5	114	81.9	46.6	20.3	13.4	8.16	5.44	2.56	0.96	0.27
ML500	87	80	27.5	143	102	58.2	25.4	16.8	10.2	6.8	3.2	1.2	0.34
ML600	87	96	27.5	172	123	69.8	30.5	20.2	12.2	8.2	3.84	1.44	0.41
ML700	87	112	27.5	201	143	81.5	35.6	23.5	14.3	9.5	4.48	1.68	0.48
ML800	87	128	27.5	229	164	93.1	40.6	26.9	16.3	10.9	5.12	1.92	0.54
ML900	87	144	27.5	258	184	105	45.72	30.2	18.4	12.2	5.76	2.16	0.61
ML1000	87	160	27.5	287	205	116	50.8	33.6	20.4	13.6	6.4	2.4	0.68
ML1100	87	176	27.5	315	225	128	55.9	37	22.4	15	7.04	2.64	0.75
ML1200	87	192	27.5	344	246	140	61	40.3	24.5	16.3	7.68	2.88	0.82
X640	87	86.4	28.3	101	78.2	43.7	22.4	14.4	9.76	8	5.3	2.4	1.07
X800	87	108	28.3	127	97.8	54.6	28	18	12.2	10	6.6	3.0	1.34
X960	87	130	28.3	152	117	65.5	33.6	21.6	14.6	12	7.92	3.6	1.61
X1120	87	151	28.3	177	137	76.4	39.2	25.2	17.1	14	9.24	4.2	1.88
X1280	87	173	28.3	203	156	87.4	44.8	28.8	19.5	16	10.6	4.8	2.14
X1440	87	194	28.3	228	176	98.3	50.4	32.4	22	18	11.9	5.4	2.41
X1600	87	216	28.3	253	196	109	56	36	24.4	20	13.2	6.0	2.68
X1760	87	238	28.3	279	215	120	61.6	39.6	26.8	22	14.5	6.6	2.95
X1920	87	259	28.3	304	235	131	67.2	43.2	29.3	24	15.8	7.2	3.22

SCFM X 28.32 = nl / m

All performance data presented is a representation of production pumps but is not a guarantee due to variations in local barometric pressure and of mass produced components.

Classic Series Pumps: Performance

Evacuation Time: sec / ft³

Model	Air Supply PSI	Air Consum SCFM	Max Vacuum inHg	Seconds to Evacuate 1 cu ft to Vacuum Level									
				3 inHg	6 inHg	9 inHg	12 inHg	15 inHg	18 inHg	21 inHg	24 inHg	26 inHg	27 inHg
E25	87	6.8	26.7	0.7	1.7	3.1	5.23	8.8	15.0	27.0	52.8	93.7	-
E50	87	13.6	26.7	0.35	0.85	1.55	2.62	4.4	7.5	13.5	26.4	46.9	-
E75	87	20.4	26.7	0.23	0.57	1.03	1.74	2.93	5.0	9.0	17.6	31.2	-
E100	87	27.2	26.7	0.18	0.43	0.79	1.31	2.2	3.75	6.75	13.2	23.4	-
E125	87	34.0	26.7	0.14	0.34	0.62	1.05	1.76	3.0	5.4	10.6	18.7	-
E150	87	40.8	26.7	0.12	0.28	0.52	0.87	1.47	2.5	4.5	8.8	15.6	-
E175	87	47.6	26.7	0.1	0.24	0.44	0.75	1.26	2.14	3.86	7.54	13.4	-
E200	87	54.4	26.7	0.088	0.21	0.39	0.65	1.1	1.88	3.38	6.6	11.7	-
E300	87	81.6	26.7	0.058	0.14	0.26	0.44	0.73	1.25	2.25	4.4	7.81	-
L25	87	4.0	22.8	0.8	1.9	3.7	6.6	12.3	19.0	33.2	-	-	-
L50	87	8.0	22.8	0.4	0.95	1.85	3.3	6.15	9.5	16.6	-	-	-
L75	87	12.0	22.8	0.27	0.63	1.23	2.2	4.1	6.3	11.1	-	-	-
L100	87	16.0	22.8	0.2	0.48	0.93	1.65	3.08	4.75	8.3	-	-	-
L125	87	20.0	22.8	0.16	0.38	0.74	1.32	2.46	3.8	6.64	-	-	-
L150	87	24.0	22.8	0.13	0.32	0.62	1.1	2.05	3.17	5.53	-	-	-
L175	87	28.0	22.8	0.11	0.27	0.53	0.94	1.76	2.71	4.74	-	-	-
L200	87	32.0	22.8	0.1	0.24	0.46	0.83	1.54	2.38	4.15	-	-	-
L300	87	48.0	22.8	0.07	0.16	0.31	0.55	1.03	1.58	2.77	-	-	-
M25	49	4.3	27.1	0.83	2.03	3.96	7.23	12.7	21.9	38.8	75.4	134	-
M50	49	8.6	27.1	0.42	1.02	1.98	3.62	6.35	11.0	19.4	37.7	67.0	-
M75	49	12.9	27.1	0.28	0.68	1.32	2.41	4.23	7.3	12.9	25.1	44.7	-
M100	49	17.2	27.1	0.21	0.51	0.99	1.81	3.18	5.48	9.7	18.9	33.5	-
M125	49	21.5	27.1	0.17	0.41	0.79	1.45	2.54	4.38	7.76	15.1	26.8	-
M150	49	25.8	27.1	0.14	0.34	0.66	1.21	2.12	3.65	6.47	12.7	22.3	-
M175	49	30.1	27.1	0.12	0.29	0.57	1.03	1.81	3.13	5.54	10.8	19.1	-
M200	49	34.4	27.1	0.1	0.25	0.5	0.9	1.59	2.74	4.85	9.43	16.8	-
M300	49	51.6	27.1	0.069	0.17	0.33	0.6	1.06	1.83	3.23	6.28	11.2	-
ML25	87	4.0	27.5	0.6	1.51	3.04	5.7	10.2	17.7	31.8	61.8	110	159
ML50	87	8.0	27.5	0.3	0.76	1.52	2.85	5.1	8.85	15.9	31.0	55.0	79.5
ML75	87	12.0	27.5	0.2	0.5	1.01	1.9	3.39	5.9	10.6	20.6	36.7	53.0
ML100	87	16.0	27.5	0.15	0.38	0.76	1.43	2.54	4.43	7.95	15.5	27.5	39.8
ML125	87	20.0	27.5	0.12	0.3	0.61	1.14	2.03	3.54	6.36	12.4	22.0	31.8
ML150	87	24.0	27.5	0.1	0.25	0.51	0.95	1.69	2.95	5.3	10.3	18.3	26.5
ML175	87	28.0	27.5	0.086	0.22	0.43	0.81	1.45	2.53	4.54	8.84	15.7	22.7
ML200	87	32.0	27.5	0.075	0.19	0.38	0.71	1.27	2.21	3.98	7.74	13.8	19.9
ML300	87	48.0	27.5	0.05	0.13	0.25	0.48	0.85	1.48	2.65	5.16	9.17	13.3
X40	87	5.4	28.3	0.69	1.71	3.38	6.21	11.0	19.1	33.9	65.6	116	167
X80	87	10.8	28.3	0.35	0.86	1.69	3.11	5.5	9.6	17.0	32.8	58.0	83.5
X120	87	16.2	28.3	0.23	0.57	1.13	2.07	3.67	6.37	11.3	21.9	38.7	55.7
X160	87	21.6	28.3	0.17	0.43	0.85	1.55	2.75	4.8	8.48	16.4	29.0	41.8
X200	87	27.0	28.3	0.14	0.34	0.68	1.24	2.2	3.8	6.78	13.4	23.2	33.4
X240	87	32.4	28.3	0.12	0.29	0.56	1.04	1.83	3.18	5.65	10.9	19.3	27.8
X280	87	37.8	28.3	0.1	0.24	0.48	0.89	1.57	2.73	4.84	9.37	16.6	23.9
X320	87	43.2	28.3	0.086	0.21	0.42	0.78	1.38	2.39	4.24	8.2	14.5	20.9
X480	87	64.8	28.3	0.058	0.14	0.28	0.52	0.92	1.59	2.83	5.47	9.6	13.9

sec / ft³ X 35.32 = sec / m³

All performance data presented is a representation of production pumps but is not a guarantee due to variations in local barometric pressure and of mass produced components.

Classic Series Pumps: Performance

Evacuation Time: sec / ft³

Model	Air Supply PSI	Air Consum SCFM	Max Vacuum inHg	Seconds to Evacuate 1 cu ft to Vacuum Level									
				3 inHg	6 inHg	9 inHg	12 inHg	15 inHg	18 inHg	21 inHg	24 inHg	26 inHg	27 inHg
E400	87	109	26.7	0.044	0.11	0.19	0.33	0.55	0.94	1.69	3.3	5.86	-
E500	87	136	26.7	0.035	0.085	0.16	0.26	0.44	0.75	1.35	2.64	4.69	-
E600	87	163	26.7	0.029	0.071	0.13	0.22	0.37	0.63	1.13	2.2	3.9	-
E700	87	190	26.7	0.025	0.061	0.11	0.19	0.31	0.54	0.96	1.89	3.35	-
E800	87	218	26.7	0.022	0.053	0.097	0.16	0.28	0.47	0.84	1.65	2.93	-
E900	87	245	26.7	0.019	0.047	0.086	0.15	0.24	0.42	0.75	1.47	2.6	-
E1000	87	272	26.7	0.018	0.043	0.078	0.13	0.22	0.38	0.68	1.32	2.34	-
E1100	87	299	26.7	0.016	0.039	0.07	0.12	0.2	0.34	0.61	1.2	2.1	-
E1200	87	326	26.7	0.015	0.035	0.065	0.11	0.18	0.31	0.56	1.1	2.0	-
L400	87	64	22.8	0.05	0.12	0.23	0.41	0.77	1.19	2.08	-	-	-
L500	87	80	22.8	0.04	0.1	0.19	0.33	0.62	0.95	1.66	-	-	-
L600	87	96	22.8	0.03	0.08	0.15	0.28	0.51	0.79	1.38	-	-	-
L700	87	112	22.8	0.029	0.07	0.13	0.24	0.44	0.68	1.19	-	-	-
L800	87	128	22.8	0.025	0.06	0.12	0.21	0.38	0.59	1.04	-	-	-
L900	87	144	22.8	0.022	0.05	0.1	0.18	0.34	0.53	0.92	-	-	-
L1000	87	160	22.8	0.02	0.048	0.09	0.17	0.31	0.48	0.83	-	-	-
L1100	87	176	22.8	0.018	0.043	0.08	0.15	0.28	0.43	0.75	-	-	-
L1200	87	192	22.8	0.017	0.04	0.077	0.14	0.26	0.40	0.69	-	-	-
M400	49	68.8	27.1	0.052	0.13	0.25	0.45	0.79	1.37	2.43	4.71	8.38	-
M500	49	86	27.1	0.042	0.1	0.2	0.36	0.64	1.1	1.94	3.77	6.7	-
M600	49	103	27.1	0.035	0.085	0.17	0.3	0.53	0.91	1.62	3.14	5.58	-
M700	49	120	27.1	0.03	0.073	0.14	0.26	0.45	0.78	1.39	2.69	4.79	-
M800	49	138	27.1	0.026	0.063	0.12	0.23	0.39	0.68	1.21	2.35	4.19	-
M900	49	155	27.1	0.023	0.056	0.11	0.2	0.35	0.61	1.08	2.09	3.72	-
M1000	49	172	27.1	0.021	0.051	0.1	0.18	0.32	0.55	0.97	1.89	3.35	-
M1100	49	189	27.1	0.019	0.046	0.09	0.16	0.29	0.5	0.88	1.71	3.05	-
M1200	49	206	27.1	0.017	0.042	0.083	0.15	0.26	0.46	0.81	1.57	2.79	-
ML400	87	34	27.5	0.038	0.094	0.19	0.36	0.64	1.12	1.99	3.87	6.88	9.94
ML500	87	80	27.5	0.03	0.076	0.15	0.29	0.51	0.89	1.59	3.1	5.5	7.95
ML600	87	96	27.5	0.025	0.063	0.13	0.24	0.42	0.74	1.33	2.58	4.58	6.63
ML700	87	112	27.5	0.021	0.054	0.11	0.2	0.36	0.63	1.14	2.21	3.93	5.68
ML800	87	128	27.5	0.019	0.047	0.095	0.18	0.32	0.55	0.99	1.93	3.44	4.97
ML900	87	144	27.5	0.017	0.042	0.084	0.16	0.28	0.49	0.88	1.72	3.06	4.42
ML1000	87	160	27.5	0.015	0.038	0.076	0.14	0.26	0.44	0.8	1.55	2.75	3.98
ML1100	87	176	27.5	0.014	0.034	0.069	0.13	0.23	0.4	0.72	1.41	2.5	3.61
ML1200	87	192	27.5	0.013	0.031	0.063	0.12	0.21	0.37	0.66	1.3	2.29	3.31
X640	87	86.4	28.3	0.043	0.11	0.21	0.39	0.69	1.19	2.12	4.1	7.25	10.4
X800	87	108	28.3	0.035	0.086	0.17	0.31	0.55	0.96	1.7	3.28	5.8	8.35
X960	87	130	28.3	0.029	0.071	0.14	0.26	0.46	0.8	1.41	2.73	4.83	6.6
X1120	87	151	28.3	0.025	0.061	0.12	0.22	0.39	0.68	1.21	2.34	4.14	5.96
X1280	87	173	28.3	0.022	0.053	0.11	0.19	0.34	0.6	1.06	2.05	3.63	5.22
X1440	87	194	28.3	0.019	0.048	0.094	0.17	0.31	0.53	0.94	1.82	3.22	4.64
X1600	87	216	28.3	0.017	0.043	0.085	0.16	0.28	0.48	0.85	1.64	2.9	4.18
X1760	87	238	28.3	0.016	0.039	0.077	0.14	0.25	0.43	0.77	1.49	2.64	3.8
X1920	87	259	28.3	0.014	0.036	0.07	0.13	0.23	0.4	0.71	1.37	2.42	3.48

sec / ft³ X 35.32 = sec / m³

All performance data presented is a representation of production pumps but is not a guarantee due to variations in local barometric pressure and of mass produced components.