

AX SERIES VACUUM PUMPS

SECTION 6

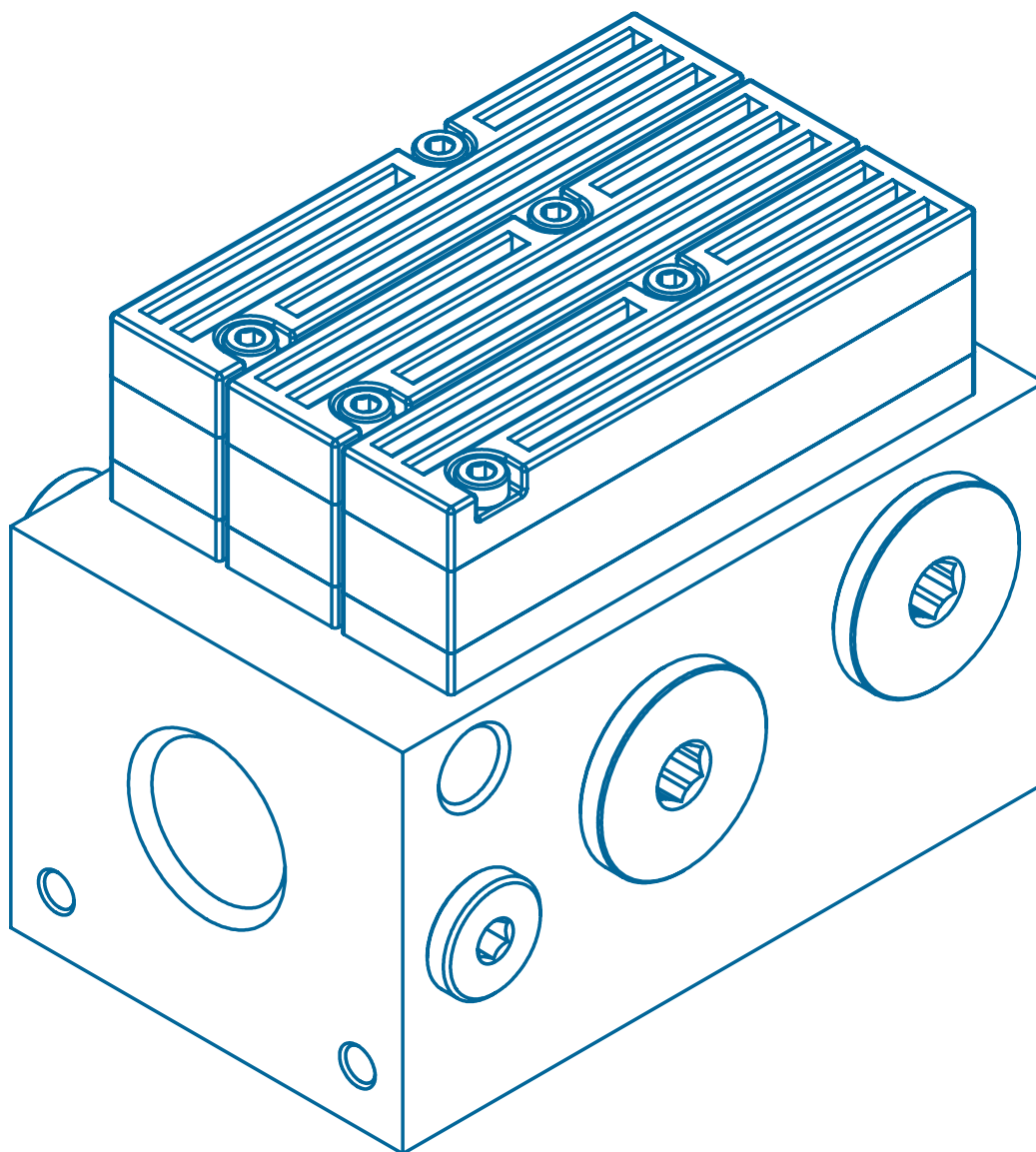

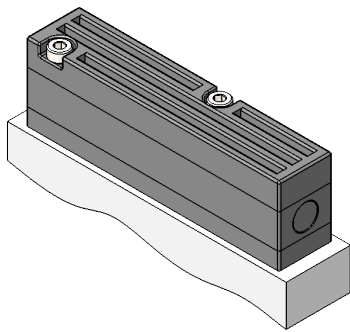

Z Option

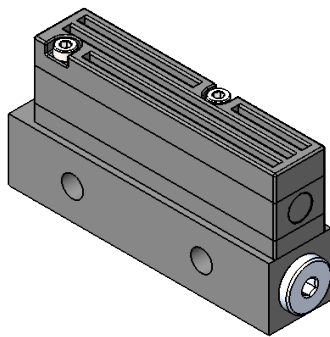

G 1/8 NPSF Bases

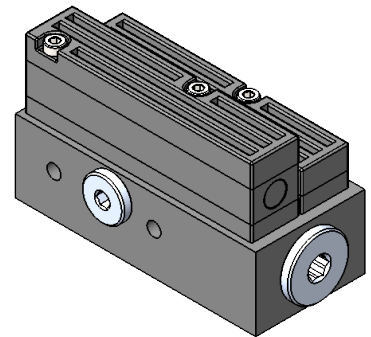

G 1/2 NPSF Bases

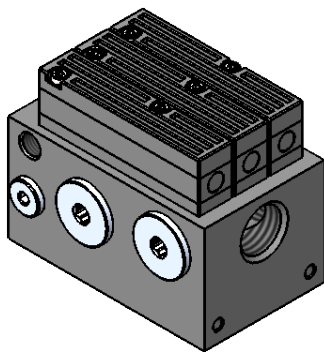

G 1/2 NPSF Bases
Large Capacity

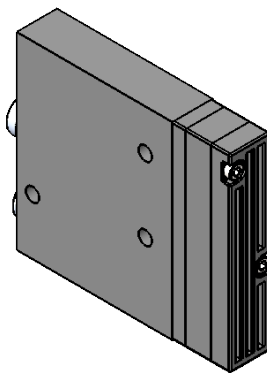

G 1/8 NPSF Bases
w/ Integral Filter

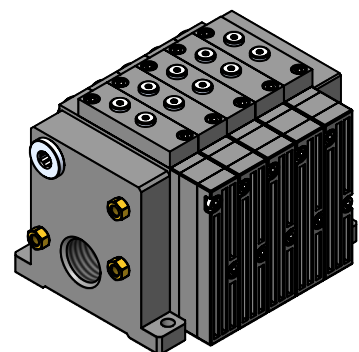

Pump Manifolds

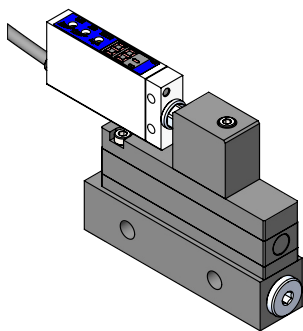

Sensor Options

Information	3
Z Option	4
G 1/8 NPSF Base	5
G 1/2 NPSF Base	5, 7
G 1/2 NPSF Base (Large Capacity)	8, 9
G 1/8 NPSF Base (Integral Filter)	10-16
Sensor Options	17
Pump Manifolds	18, 19
Performance	20-23

AX Series Vacuum Pumps

EDCO USA AX Series multi-stage vacuum pumps provide a wide array of styles and configurations to meet your system requirements.

- Modular design allows for stacking up to four pump capacities.
- Wide-range ejector nozzles can operate from 45 to 87 psi [3 to 6 bar].
- Proven coaxial technology provides greater efficiency than conventional ejectors.
- M-Series ejectors may be operated at low air feed pressure for protection from fluctuating factory air-supply pressures.
- L-Series ejectors produce high-vacuum flow suitable for handling porous objects or overcoming other system leakage.
- AX pumps operate at a lower air-pressure so fluctuations in plant air pressure will not affect vacuum pump performance.
- Multi-stage pump modules allow for fast evacuation and greater efficiency.
- Integrated solenoid valves eliminate extra plumbing. Low-power 24 V DC, 1.3 W coils are employed to reduce loads on PLC controllers.
- Choose from solenoid controlled, air-pilot controlled, or simple air-supply controls.
- Integrated solenoid valves control blow-off with adjustable flow controls are available.
- Automatic blow-off modules for single-input controls are available.
- Choose from a variety of different vacuum switches for system monitoring.
- Vacuum filters are replaceable.
- Manifold versions with 1 to 10 stations in common or separate air-supply configurations with control and sensing options are available.
- Manifolds include piped exhaust. Exhaust silencers are optional.
- High-quality finish includes anodizing or electroless nickel plating, stainless steel fasteners, stainless steel tie-rods, and glass-reinforced PPS pump modules and valve plates.
- Choose from many standard EDCO pump bases or selection the Z Base option for integration into your custom design.
- AX series vacuum pumps come fully factory assembled and ready for installation.

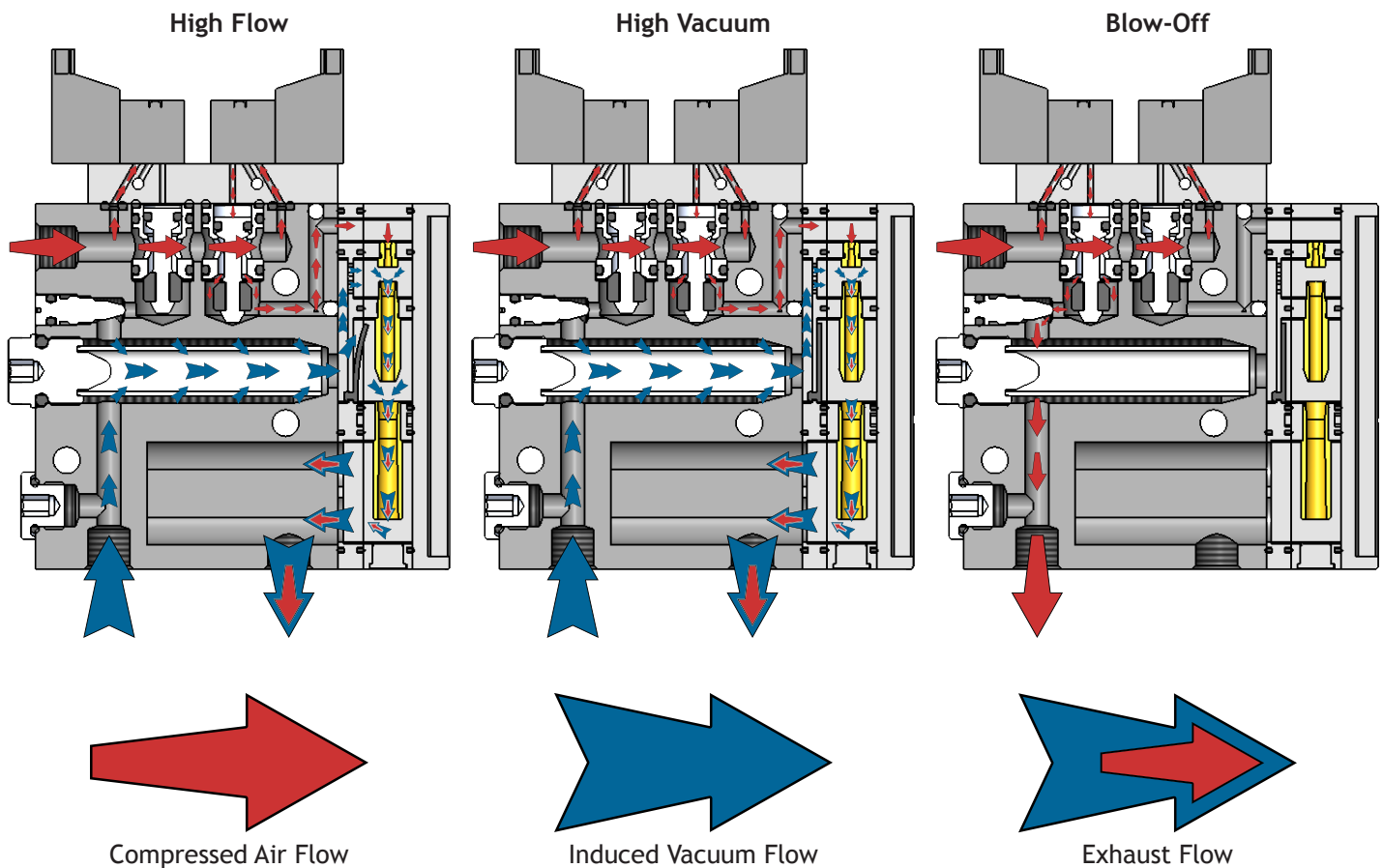

AX Pump - Z Option (Zero / No Base)

- Complete pump module ready for integration into your custom design.
- M3 mounting screws and pump seals are included.
- Can be configured with one or two pump modules for more vacuum flow capacity.

Series	Capacity	Non-Return Option		
AX	L	1	N	-Z
L	L-Series	1	1 Ejector	(Blank) No
M	M-Series	2	2 Ejectors	R Non-Return

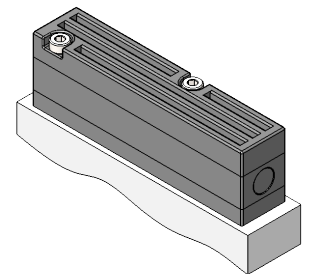
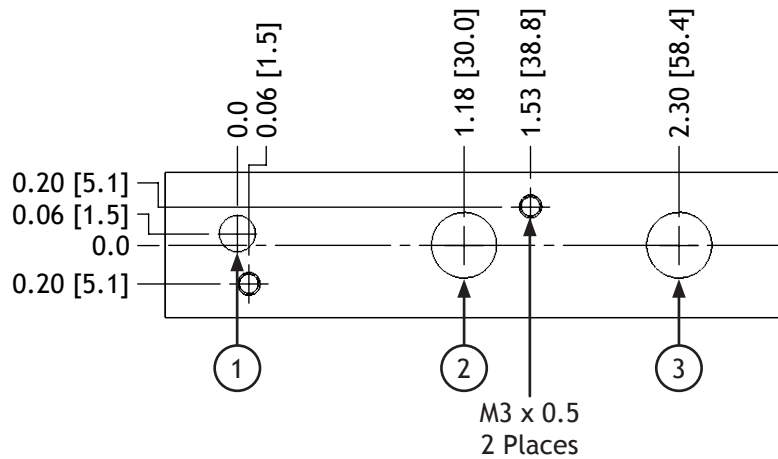
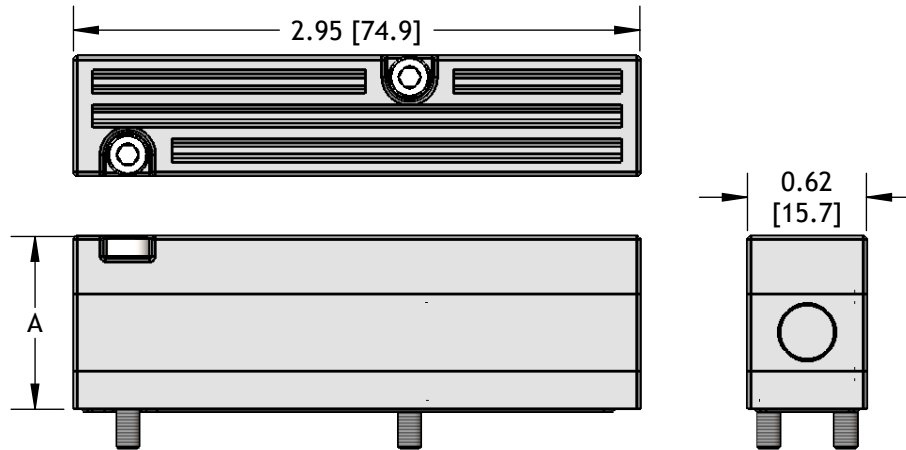

Capacity	A in [mm]	Weight oz [g]
1	0.90 [22.9]	1.71 [48.4]
2	1.30 [33.1]	2.44 [69.3]

Code	Function	Hole Ø in [mm]
1	Air Supply	0.19 [4.8]
2	Vacuum	0.34 [8.6]
3	Exhaust	0.34 [8.6]

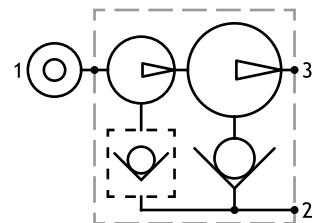

AX Pump - G 1/8 NPSF Base

- Basic pump with two exhaust ports at 90° - use the one most suitable for your application.
- Can be configured with one or two pump modules for more vacuum flow capacity.

Series		Capacity		Non-Return Option		Sensor Option		Silencer Option	
AX	L	1	N	-18					
L	L-Series	1	1 Ejector	(Blank)	No	(Blank)	None	(Blank)	None
M	M-Series	2	2 Ejectors	R	Non-Return	-VA3	VA-3	-ST	STA18M
						-VN3	VN-3		
						-VN4	VN-4		
						-VP4	VP-4		
						-61N	DVN-61-18M		
						-61P	DVP-61-18M		
						-62N	DVN-62-18M		
						-100N	DVN-100		
						-100P	DVP-100		

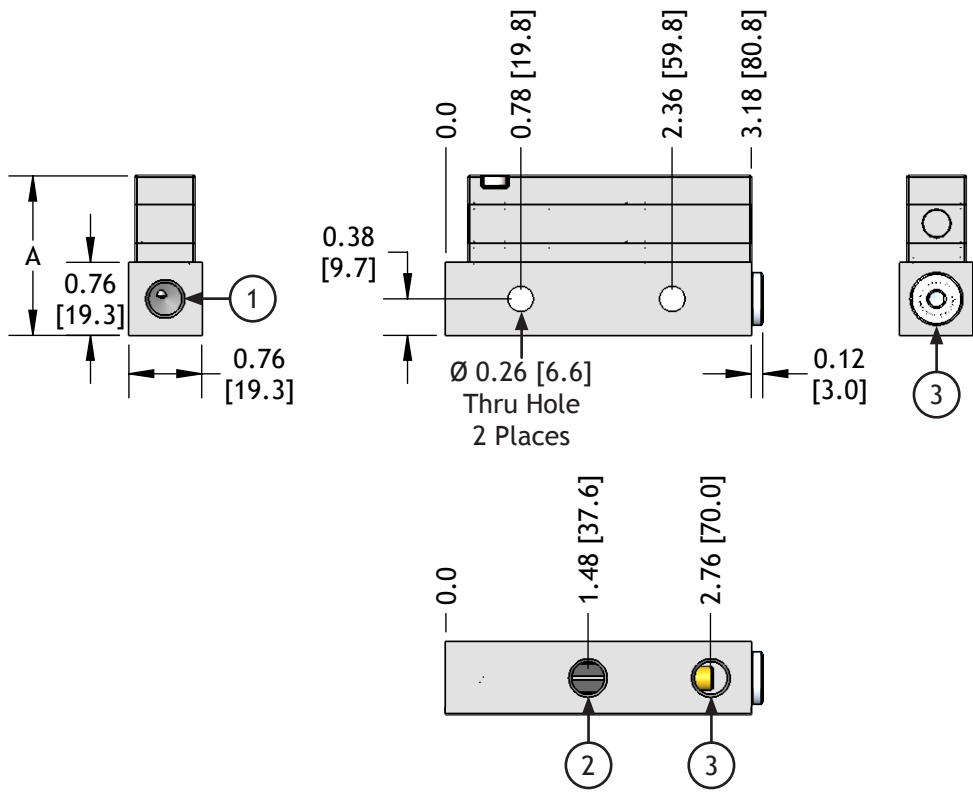

Capacity	A in [mm]	Weight oz [g]
1	1.66 [42.2]	4.19 [118.7]
2	2.06 [52.4]	4.92 [139.6]

Code	Function	Ports
1	Air Supply	G 1/8 NPSF
2	Vacuum	G 1/8 NPSF
3	Exhaust	G 1/8 NPSF

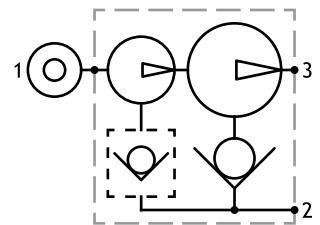
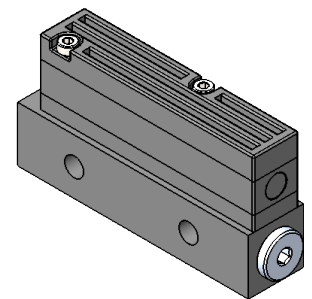

AX Pump - G 1/2 NPSF Base

- Basic pump includes two exhaust ports at 90° - use the port most suitable for your application.
- Configurable with one to four pump modules for more vacuum flow capacity.
- Two side auxiliary vacuum ports are included.

Series	Capacity	Non-Return Option		Sensor Option		Silencer Option	
AX	L 2 N	-12					
L	L-Series	1	1 Ejectors	(Blank)	None	(Blank)	None
M	M-Series	2	2 Ejectors	R	Non-Return	-VA3	VA-3
		3	3 Ejectors			-VN3	VN-3
		4	4 Ejectors			-VN4	VN-4
						-VP4	VP-4
						-61N	DVN-61-18M
						-61P	DVP-61-18M
						-62N	DVN-62-18M
						-100N	DVN-100
						-100P	DVP-100

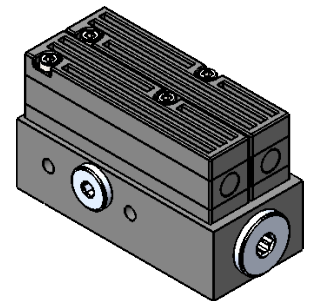
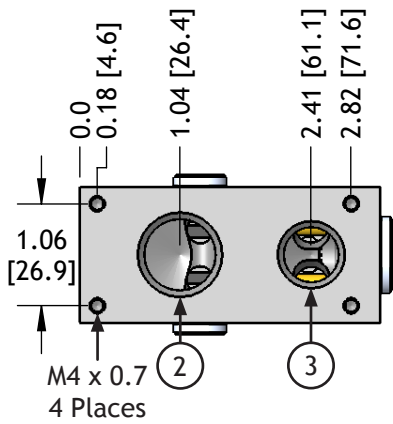
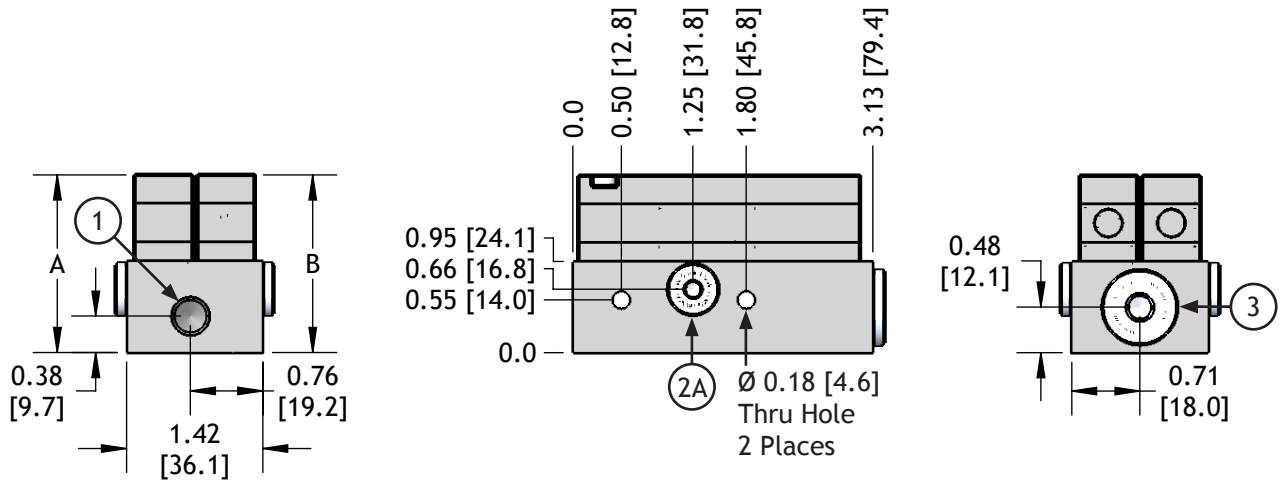

Capacity	A in [mm]	B in [mm]	Weight oz [g]
1	1.85 [47.0]	1.45 [66.8]	8.03 [227.8]
2	1.85 [47.0]	1.85 [47.0]	8.73 [247.6]
3	2.25 [57.2]	1.85 [47.0]	9.43 [267.4]
4	2.25 [57.2]	2.25 [57.2]	10.13 [287.2]

Code	Function	Ports
1	Air Supply	G 1/8 NPSF
2	Vacuum - Main	G 1/2 NPSF
2A	Vacuum - Alternate	G 1/8 NPSF
3	Exhaust	3/8 NPSF

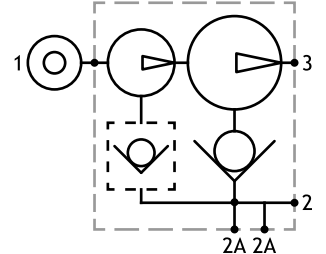

AX Pump - G 1/2 NPSF Base w/ Solenoid Supply

- Normally-closed solenoid valve controls vacuum-on, 24V DC, 1.3 W coil.
- Order solenoid cables separately. SV10-QD-1M (See system accessories.)
- Basic pump includes two exhaust ports at 90° - use the port most suitable for your application.
- Configurable with one to four pump modules for more vacuum flow capacity.
- Two side auxiliary vacuum ports are included.

Series	Capacity	Non-Return Option		Sensor Option		Silencer Option	
AX	L 2	N	-12S24D				
L	L-Series	1	1 Ejectors	(Blank)	None	(Blank)	None
M	M-Series	2	2 Ejectors	R	Non-Return	-VA3	VA-3
		3	3 Ejectors			-VN3	VN-3
		4	4 Ejectors			-VN4	VN-4
						-VP4	VP-4
						-61N	DVN-61-18M
						-61P	DVP-61-18M
						-62N	DVN-62-18M
						-100N	DVN-100
						-100P	DVP-100

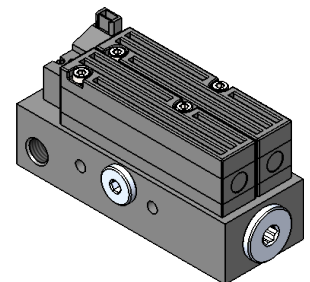
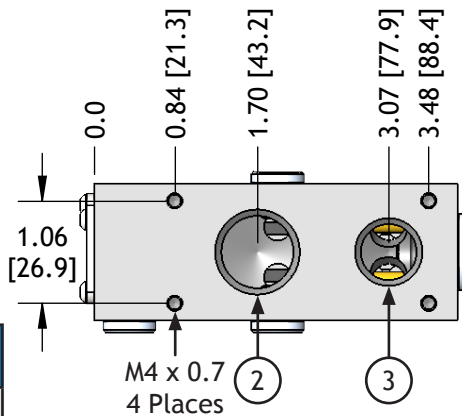
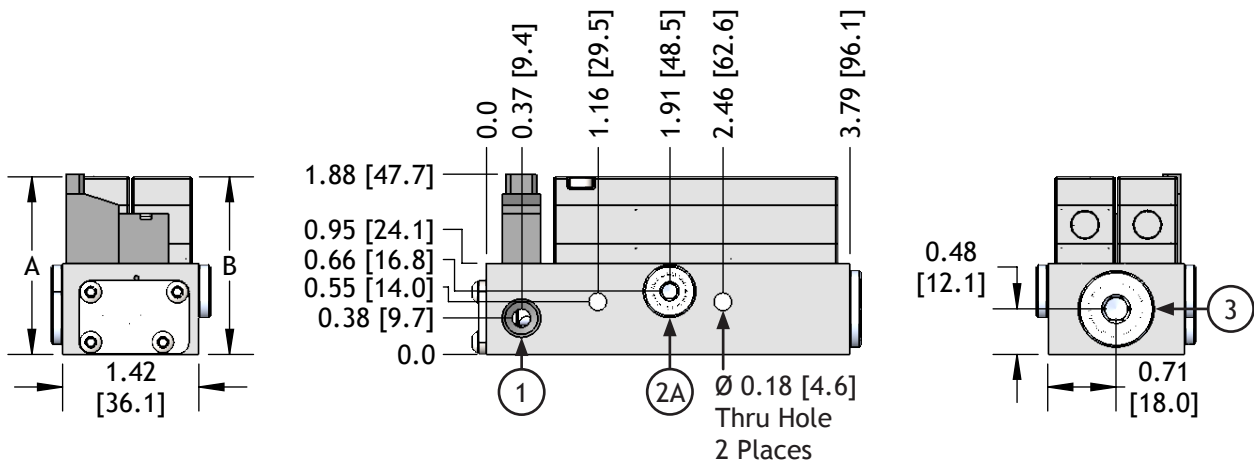

Capacity	A in [mm]	B in [mm]	Weight oz [g]
1	1.85 [47.0]	1.45 [66.8]	9.78 [277.4]
2	1.85 [47.0]	1.85 [47.0]	10.48 [297.2]
3	2.25 [57.2]	1.85 [47.0]	11.18 [316.9]
4	2.25 [57.2]	2.25 [57.2]	11.88 [336.7]

Code	Function	Ports
1	Air Supply	G 1/8 NPSF
2	Vacuum - Main	G 1/2 NPSF
2A	Vacuum - Alternate	G 1/8 NPSF
3	Exhaust	3/8 NPSF

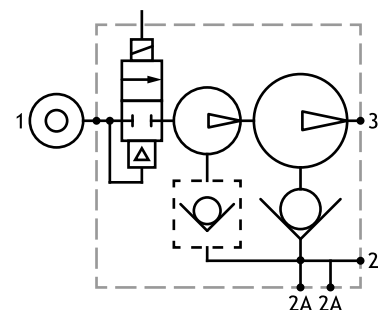

AX Pump - G 1/2 NPSF Base for Large Capacities

- Modular design includes rugged aluminum base for ease of installation and servicing.
- Three 1/2" pump vacuum ports simplify vacuum system plumbing - use the most convenient ports and plug the rest.
- Low noise level and fast evacuation times.
- Optional vacuum gauge, exhaust silencer, and foot-mount brackets are available.

Series	Capacity	Non-Return Option		Ports		Sensor Option		Silencer Option	
AX	L 3 N	(Blank)	None	(Blank)	NPT	(Blank)	None	(Blank)	None
L	L-Series 2 2 Ejectors	R	Non-Return	G	G Threads	-VA3	VA-3	-ST	STC12M
M	M-Series 3 3 Ejectors					-VN3	VN-3		
	4 4 Ejectors					-VN4	VN-4		
	5 5 Ejectors					-VP4	VP-4		
	6 5 Ejectors					-61N	DVN-61-18M		
						-61P	DVP-61-18M		
						-62N	DVN-62-18M		
						-100N	DVN-100		
						-100P	DVP-100		

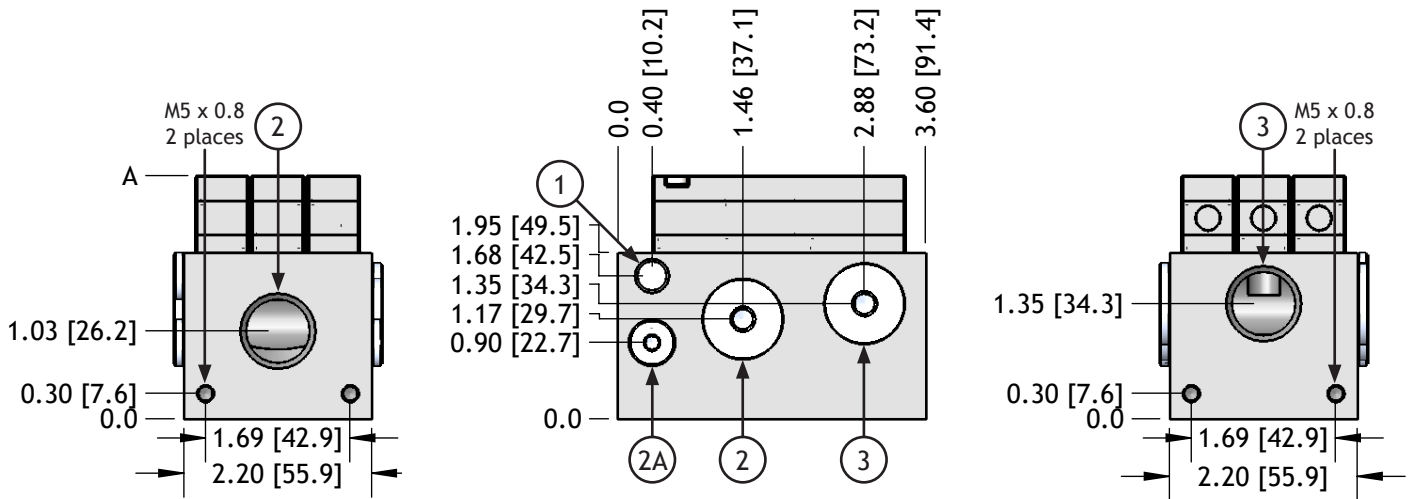

Capacity	A in [mm]	Weight oz [g]
2	1.85 [47.0]	686.11 [24.2]
3	1.85 [47.0]	705.9 [24.9]
4	2.25 [57.2]	725.68 [25.6]
5	2.25 [57.2]	745.47 [26.3]
6	2.25 [57.2]	765.25 [27.0]

Code	Function	NPT	G
1	Air Supply	G 1/8 NPSF	
2	Vacuum - Main	1/2 NPTF	G 1/2
2A	Vacuum - Alternate	G 1/8 NPSF	
3	Exhaust	1/2 NPTF	G 1/2
M	Mounting	1/4-20	M6 x 1.0

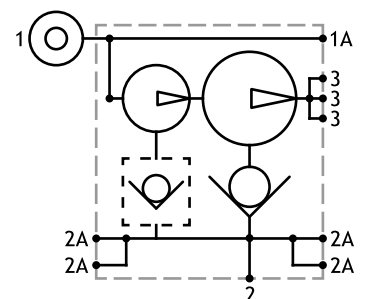
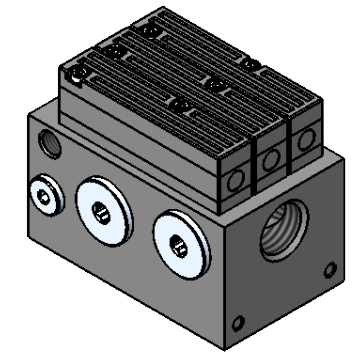

AX-312 Base Mounting Brackets

Stainless steel mounting brackets attach to the ends of the base. Straight and right angle versions are available.

M5 SHCS (qty 2) Included for easy mounting.

Additional Weight: 1.29 oz [36.4 g]

	Style
AX-312-BKT-	90
	90 90° Bracket
	180 180° Bracket

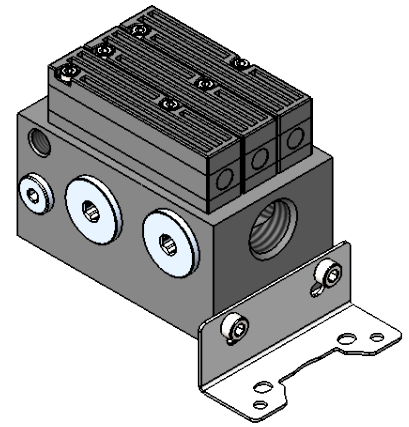

AX-312-BKT-90

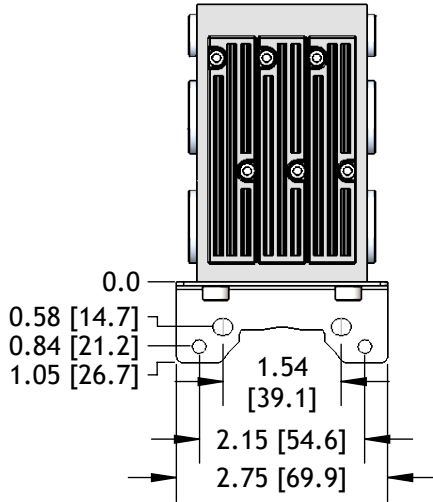

AX-312-BKT-180

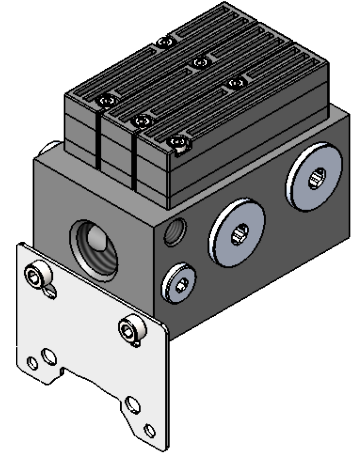
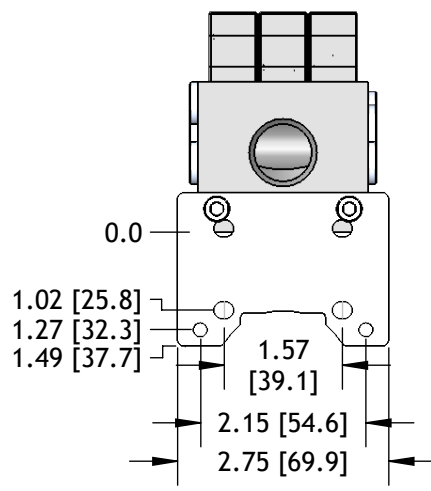

AX Pump - G 1/8 NPSF Base w/ Integral Filter

- Pump with filter and two vacuum ports at 90° - use the most convenient port.
- Configurable with one or two pump modules for more vacuum flow capacity.
- RE10X50 filter element included.

Series	Capacity	Non-Return Option		Sensor Option		Silencer Option	
AX	L	1	N	-F18			
L	L-Series	1	1 Ejector	(Blank)	None	(Blank)	None
M	M-Series	2	2 Ejectors	R	Non-Return	-ST	STA18M
				-VA3	VA-3		
				-VN3	VN-3		
				-VN4	VN-4		
				-VP4	VP-4		
				-61N	DVN-61-18M		
				-61P	DVP-61-18M		
				-62N	DVN-62-18M		
				-100N	DVN-100		
				-100P	DVP-100		

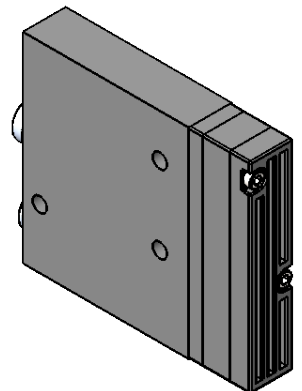
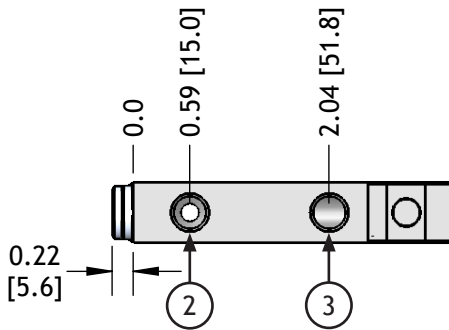
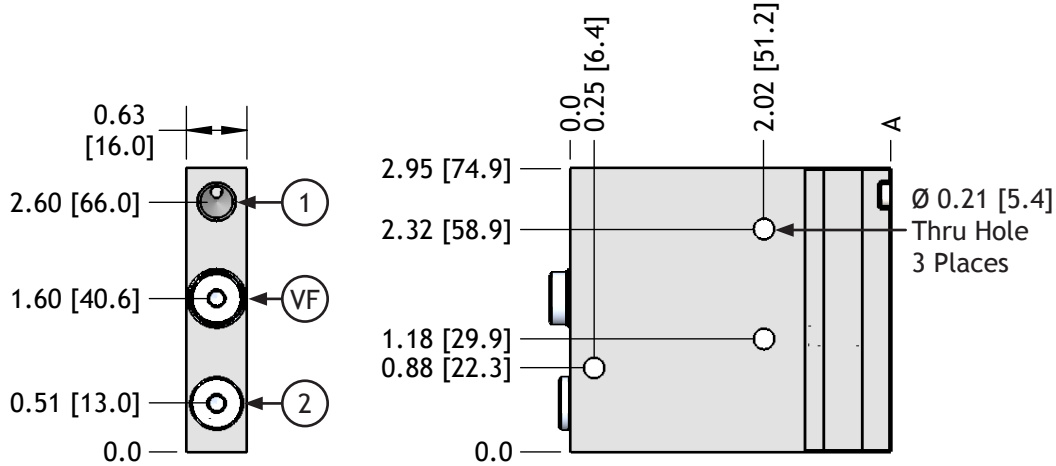

Capacity	A in [mm]	Weight oz [g]
1	3.34 [84.8]	7.00 [198.7]
2	3.74 [95.0]	7.71 [218.5]

Code	Function	Ports
1	Air Supply	G 1/8 NPSF
2	Vacuum	G 1/8 NPSF
3	Exhaust	G 1/8 NPSF
VF	Vacuum Filter	-

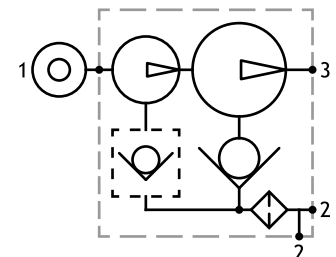

AX Pump - G 1/8 NPSF Base w/ Integral Filter & Piloted Supply

- Pump with filter and two vacuum ports at 90° - use the most convenient port.
- Includes internal, air-piloted air supply control valve.
- Configurable with one or two pump modules for more vacuum flow capacity.
- RE10X50 filter element included.

Series	Capacity	Non-Return Option		Sensor Option		Silencer Option	
AX	L	1	N	-F18PS			
L	L-Series	1	1 Ejector	(Blank)	None	(Blank)	None
M	M-Series	2	2 Ejectors	R	Non-Return	-ST	STA18M
				-VA3	VA-3		
				-VN3	VN-3		
				-VN4	VN-4		
				-VP4	VP-4		
				-61N	DVN-61-18M		
				-61P	DVP-61-18M		
				-62N	DVN-62-18M		
				-100N	DVN-100		
				-100P	DVP-100		

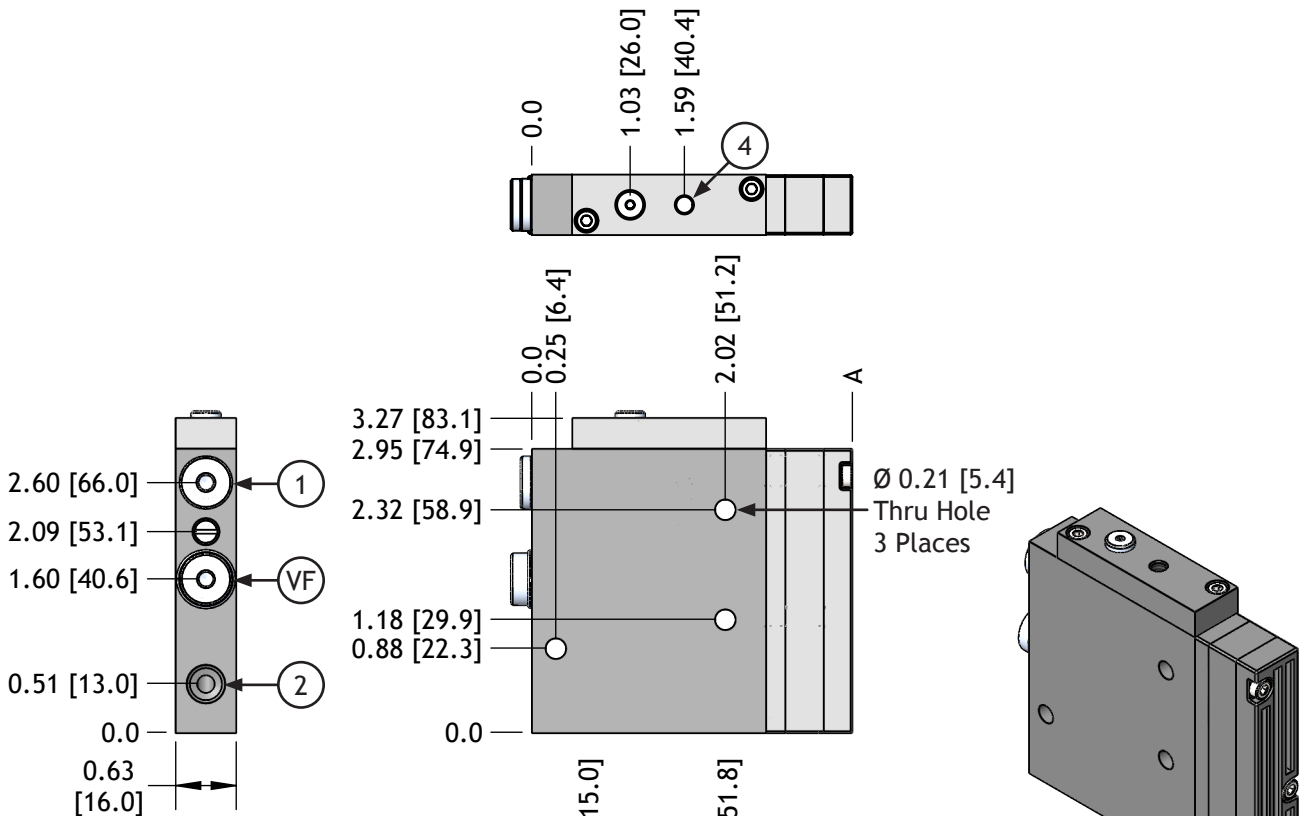

Capacity	A in [mm]	Weight oz [g]
1	3.34 [84.8]	7.44 [211.0]
2	3.74 [95.0]	8.14 [230.8]

Code	Function	Ports
1	Air Supply	G 1/8 NPSF
2	Vacuum	G 1/8 NPSF
3	Exhaust	G 1/8 NPSF
4	Pilot, Vacuum	M5 x 0.8 (10-32)
VF	Vacuum Filter	-

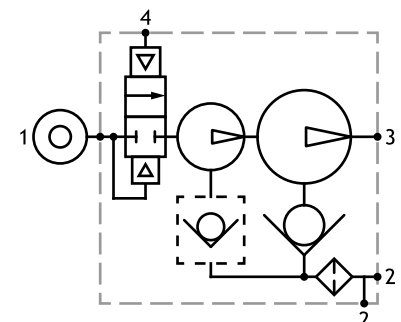
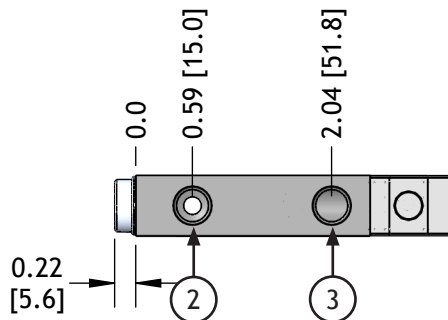

AX Pump - G 1/8 NPSF Base w/ Integral Filter & Piloted Supply & Blow-Off

- Pump with filter and two vacuum ports at 90° - use the most convenient port.
- Includes internal, air-piloted air supply control valve and internal, air-piloted blow-off control valve with adjustable flow control.
- Configurable with one or two pump modules for more vacuum flow capacity.
- RE10X50 filter element included.

Series		Capacity		Non-Return Option		Sensor Option		Silencer Option	
AX	L	1	N	-F18PSB					
L	L-Series	1	1 Ejector	(Blank)	None	(Blank)	None	(Blank)	None
M	M-Series	2	2 Ejectors	R	Non-Return	-VA3	VA-3	-ST	STA18M
						-VN3	VN-3		
						-VN4	VN-4		
						-VP4	VP-4		
						-61N	DVN-61-18M		
						-61P	DVP-61-18M		
						-62N	DVN-62-18M		
						-100N	DVN-100		
						-100P	DVP-100		

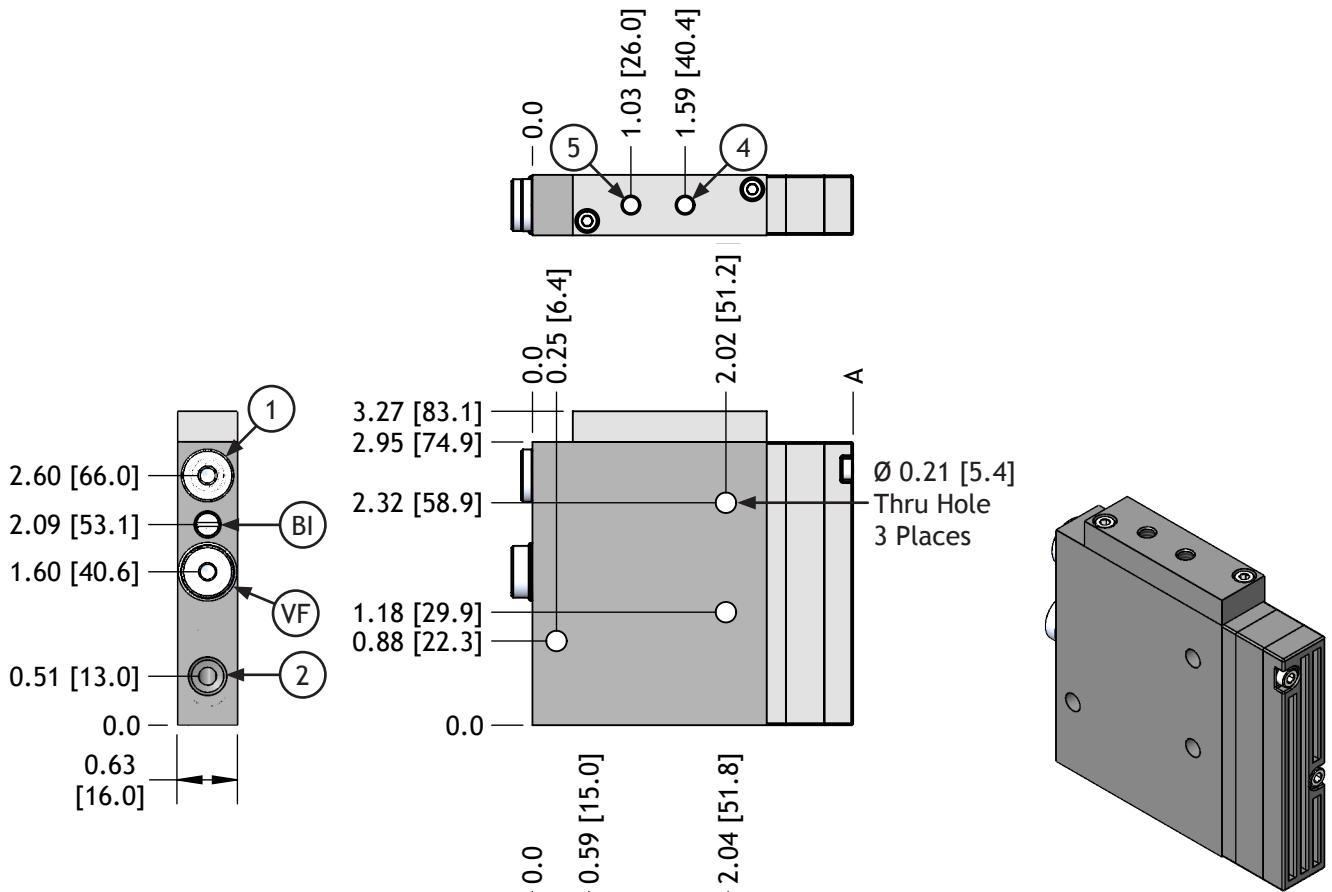

Code	Function	Ports
1	Air Supply	G 1/8 NPSF
2	Vacuum	G 1/8 NPSF
3	Exhaust	G 1/8 NPSF
4	Pilot, Vacuum	M5 x 0.8 (10-32)
5	Pilot, Blow-Off	M5 x 0.8 (10-32)
BI	Blow-Off Intensity	-
VF	Vacuum Filter	-

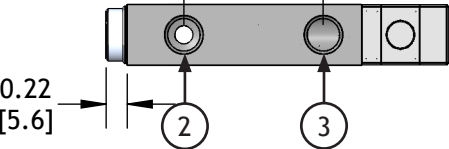

Capacity	A in [mm]	Weight oz [g]
1	3.34 [84.8]	7.43 [210.8]
2	3.74 [95.0]	8.13 [230.6]

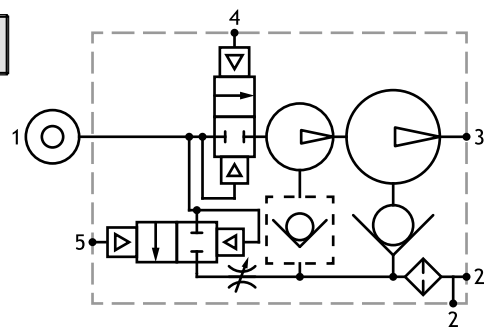

AX Pump - G 1/8 NPSF Base w/ Integral Filter & Solenoid Supply

- Pump with filter and two vacuum ports at 90° - use the most convenient port.
- Normally-closed solenoid valve (24V DC, 1.3W coil) controls vacuum-on. (Order cable separately. SV10-QD-1M)
- Configurable with one or two pump modules for more vacuum flow capacity.
- RE10X50 filter element included.

Series	Capacity	Non-Return Option		Sensor Option		Silencer Option	
AX	L	1	N	-F18S24D			
L	L-Series	1	1 Ejector	(Blank)	None	(Blank)	None
M	M-Series	2	2 Ejectors	R	Non-Return	-VA3	VA-3
						-VN3	VN-3
						-VN4	VN-4
						-VP4	VP-4
						-61N	DVN-61-18M
						-61P	DVP-61-18M
						-62N	DVN-62-18M
						-100N	DVN-100
						-100P	DVP-100

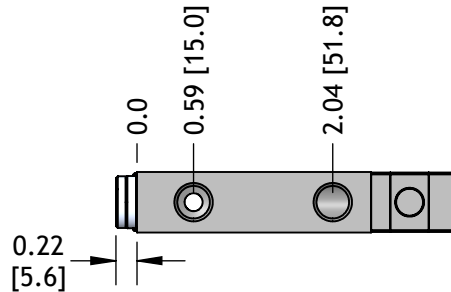
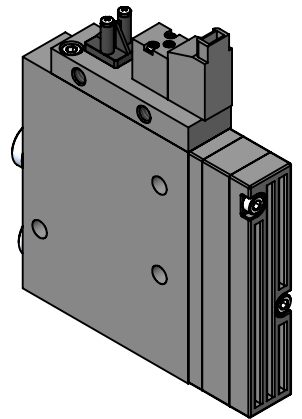
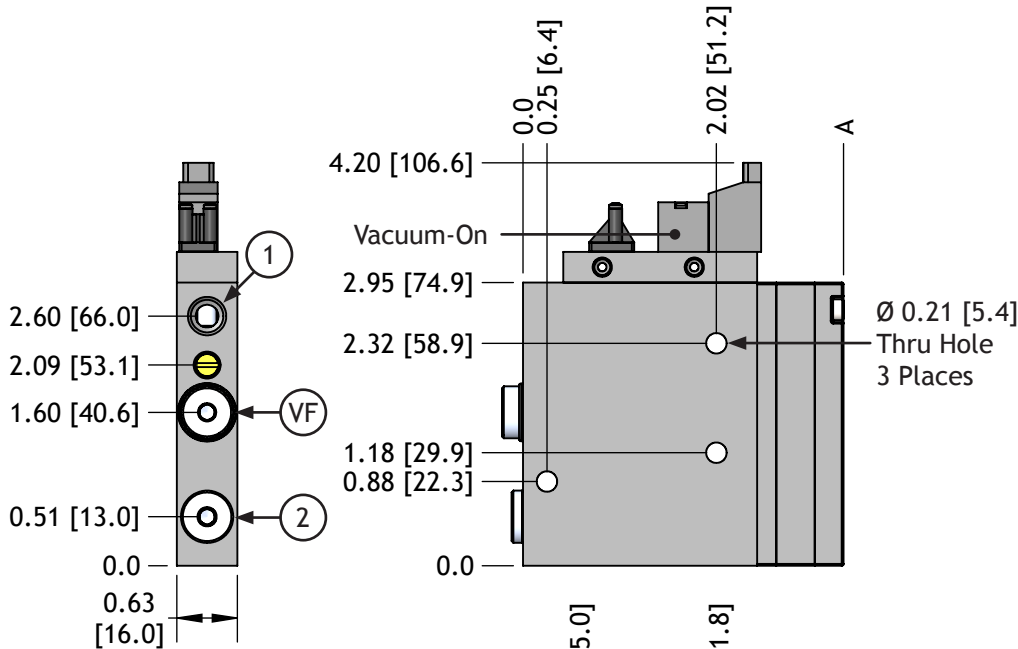
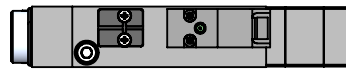

Capacity	A in [mm]	Weight oz [g]
1	3.34 [84.8]	7.58 [214.9]
2	3.74 [95.0]	8.28 [234.7]

Code	Function	Ports
1	Air Supply	G 1/8 NPSF
2	Vacuum	G 1/8 NPSF
3	Exhaust	G 1/8 NPSF
VF	Vacuum Filter	-

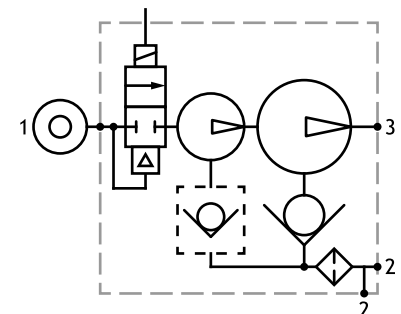

AX Pump - G 1/8 NPSF Base w/ Integral Filter & Solenoid Supply & Blow-Off

- Pump with filter and two vacuum ports at 90° - use the most convenient port.
- Normally-closed solenoid valve (24V DC, 1.3W coil) controls vacuum-on.
- Normally-closed solenoid valve (24V DC, 1.3W coil) controls blow-off (with adjustable flow control).
- Order solenoid cables separately. SV10-QD-1M
- Configurable with one or two pump modules for more vacuum flow capacity.
- RE10X50 filter element included.

Series	Capacity	Non-Return Option		Sensor Option		Silencer Option	
AX	L	1	N	-F18SB24D			
L	L-Series	1	1 Ejector	(Blank)	None	(Blank)	None
M	M-Series	2	2 Ejectors	R	Non-Return	-VA3	VA-3
						-VN3	VN-3
						-VN4	VN-4
						-VP4	VP-4
						-61N	DVN-61-18M
						-61P	DVP-61-18M
						-62N	DVN-62-18M
						-100N	DVN-100
						-100P	DVP-100

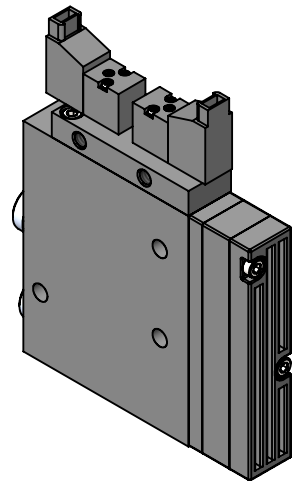
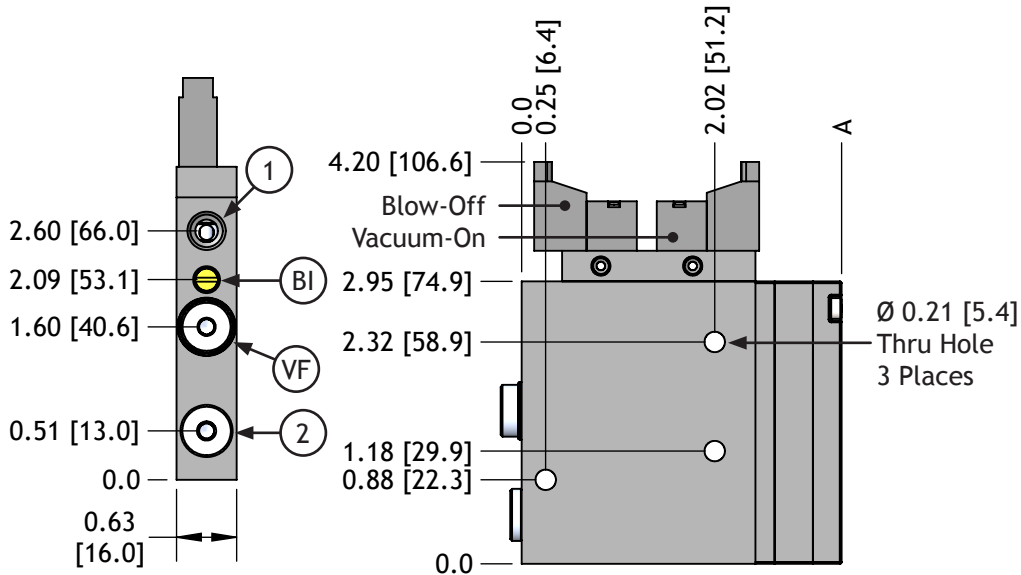
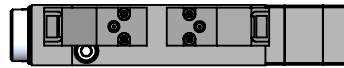

Capacity	A in [mm]	Weight oz [g]
1	3.34 [84.8]	7.71 [218.6]
2	3.74 [95.0]	8.41 [238.4]

Code	Function	Ports
1	Air Supply	G 1/8 NPSF
2	Vacuum	G 1/8 NPSF
3	Exhaust	G 1/8 NPSF
BI	Blow-off Intensity	-
VF	Vacuum Filter	-

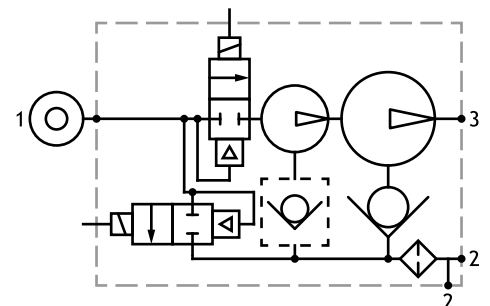
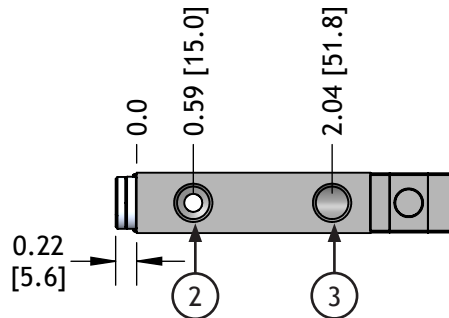

AX Pump - G 1/8 NPSF Base w/ Integral Filter & Solenoid Supply (N.O.)

- Pump with filter and two vacuum ports at 90° - use the most convenient port.
- Normally-opened solenoid valve (24V DC, 1.3W coil) controls vacuum-off. (Order cable separately. SV10-QD-1M)
- Normally-on vacuum retains parts in the event of a power failure.
- Configurable with one or two pump modules for more vacuum flow capacity.
- RE10X50 filter element included.

Series		Capacity		Non-Return Option		Sensor Option		Silencer Option	
AX	L	1	N	-F180S24D		(Blank)	None	(Blank)	None
L	L-Series	1	1 Ejector	(Blank)	None	(Blank)	None	(Blank)	None
M	M-Series	2	2 Ejectors	R	Non-Return	-VA3	VA-3	-ST	STA18M
						-VN3	VN-3		
						-VN4	VN-4		
						-VP4	VP-4		
						-61N	DVN-61-18M		
						-61P	DVP-61-18M		
						-62N	DVN-62-18M		
						-100N	DVN-100		
						-100P	DVP-100		

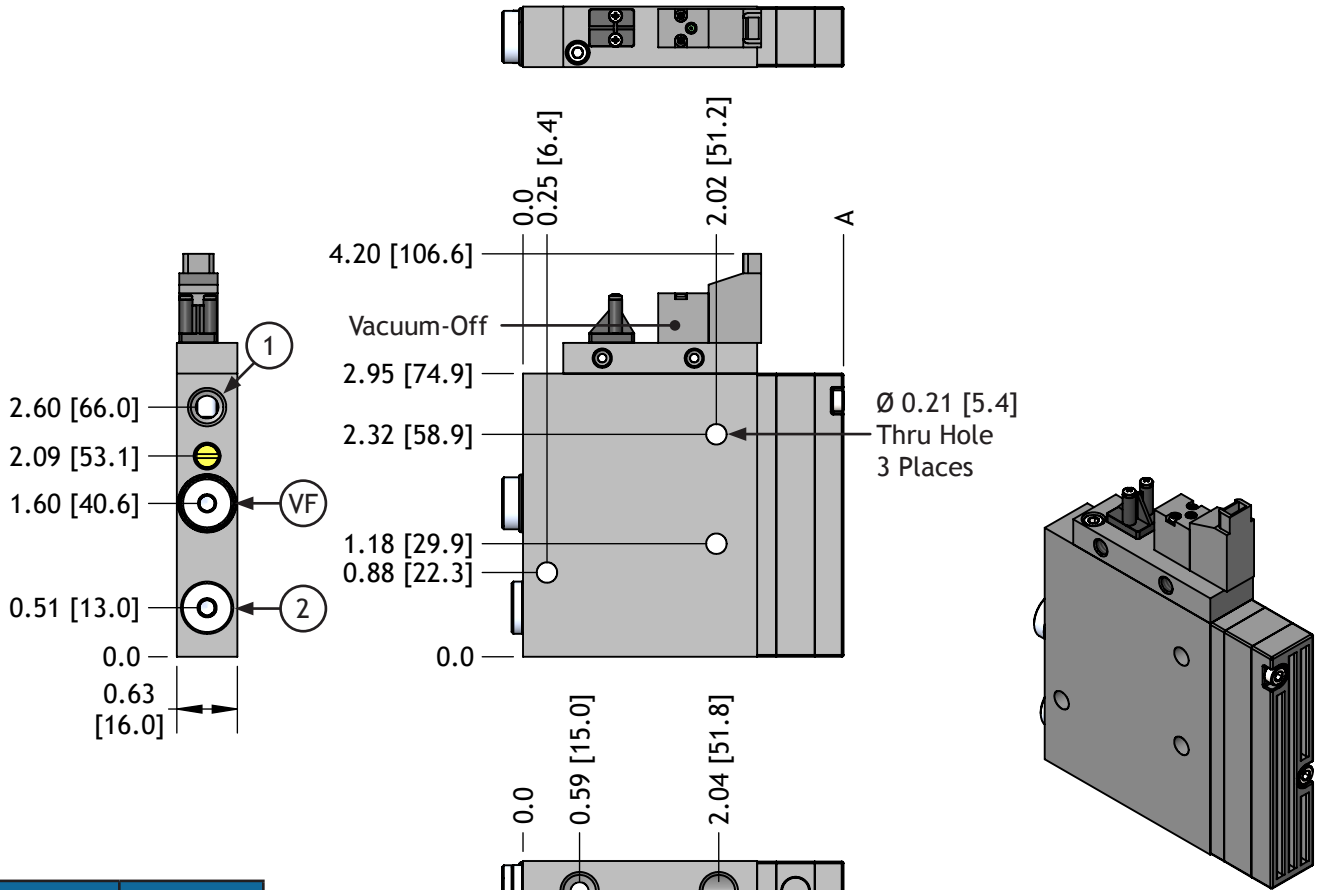

Capacity	A in [mm]	Weight oz [g]
1	3.34 [84.8]	7.58 [214.9]
2	3.74 [95.0]	8.28 [234.7]

Code	Function	Ports
1	Air Supply	G 1/8 NPSF
2	Vacuum	G 1/8 NPSF
3	Exhaust	G 1/8 NPSF
VF	Vacuum Filter	-

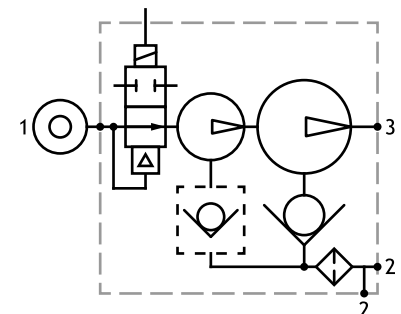

AX Pump - G 1/8 NPSF Base w/ Integral Filter & Solenoid Supply (N.O.) & Blow-Off

- Pump with filter and two vacuum ports at 90° - use the most convenient port.
- Normally-opened solenoid valve (24V DC, 1.3W coil) controls vacuum-off.
- Normally-on vacuum retains parts in the event of a power failure.
- Normally-closed solenoid valve (24V DC, 1.3W coil) controls blow-off (with adjustable flow control).
- Order solenoid cables separately. SV10-QD-1M
- Configurable with one or two pump modules for more vacuum flow capacity.
- RE10X50 filter element included.

Series	Capacity	Non-Return Option		Sensor Option		Silencer Option	
AX	L	1	N	-F180SB24D			
L	L-Series	1	1 Ejector	(Blank)	None	(Blank)	None
M	M-Series	2	2 Ejectors	R	Non-Return	-VA3	VA-3
						-VN3	VN-3
						-VN4	VN-4
						-VP4	VP-4
						-61N	DVN-61-18M
						-61P	DVP-61-18M
						-62N	DVN-62-18M
						-100N	DVN-100
						-100P	DVP-100

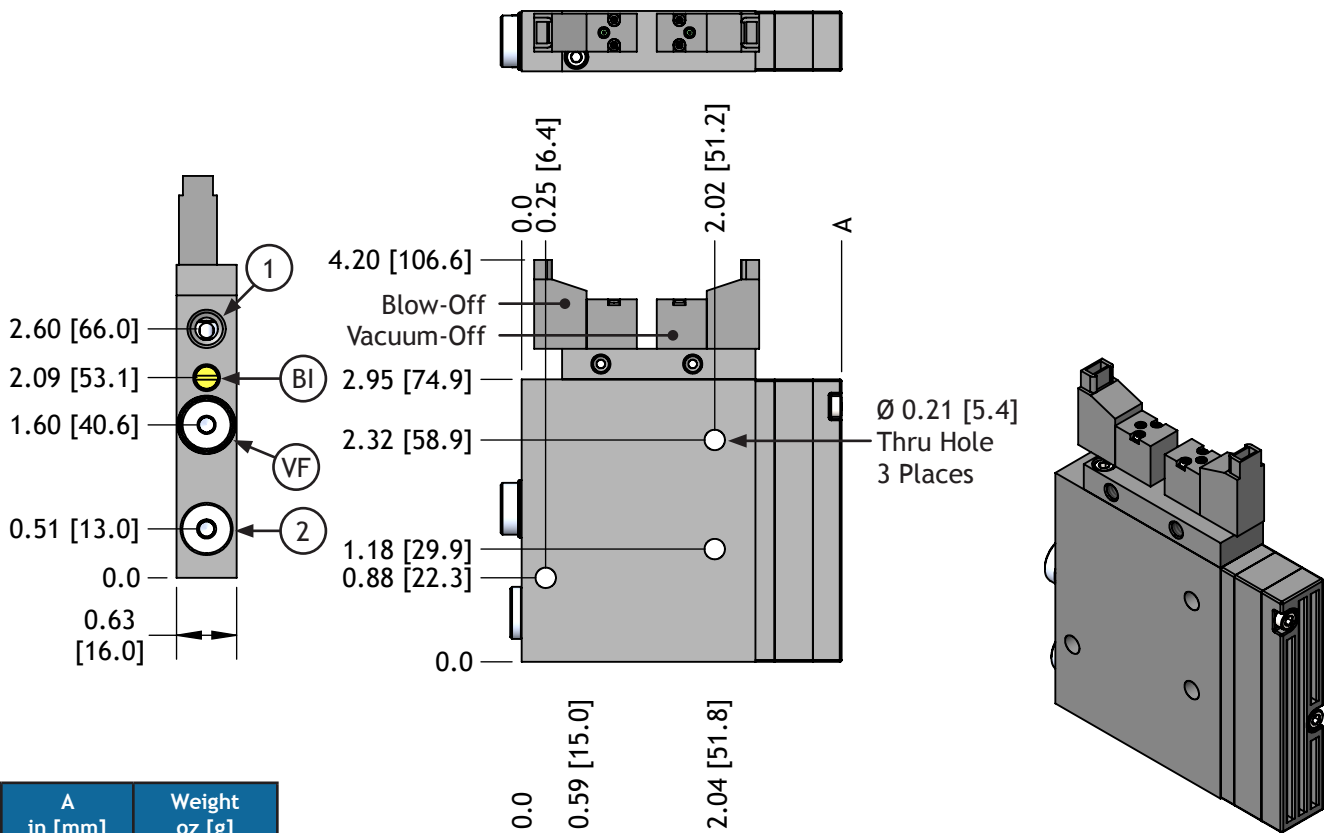

Capacity	A in [mm]	Weight oz [g]
1	3.34 [84.8]	7.71 [218.6]
2	3.74 [95.0]	8.41 [238.4]

Code	Function	Ports
1	Air Supply	G 1/8 NPSF
2	Vacuum	G 1/8 NPSF
3	Exhaust	G 1/8 NPSF
BI	Blow-off Intensity	-
VF	Vacuum Filter	-

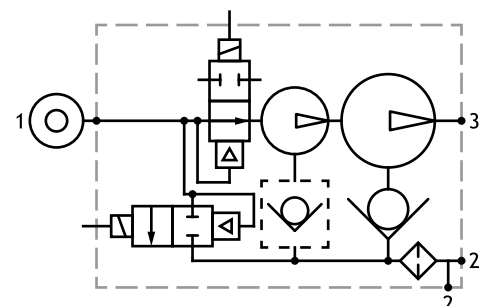
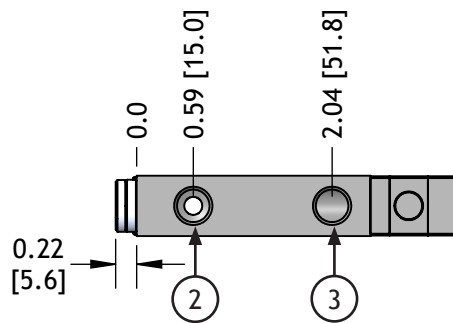

AX Series Vacuum Pump Sensor Options
-61 / -62 Series Sensor Options

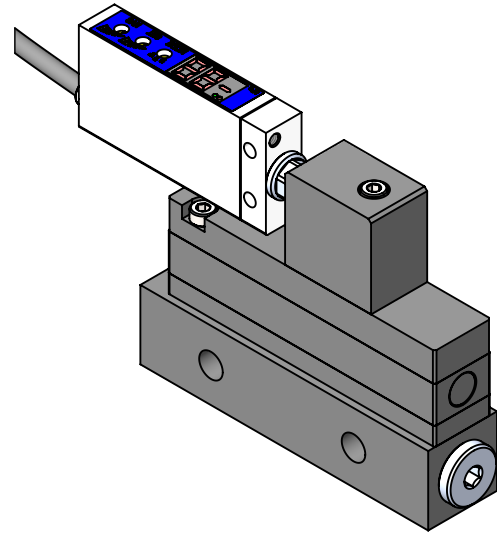
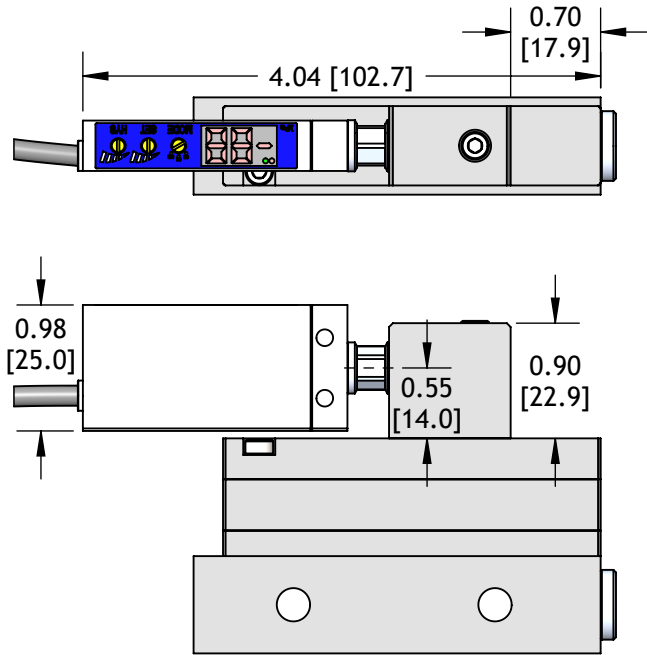

Additional Weight: 0.45 oz [12.8 g]

V Series Sensor Options

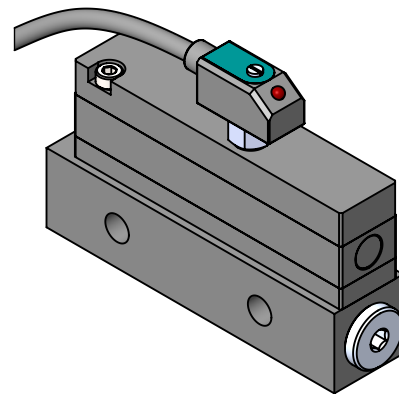
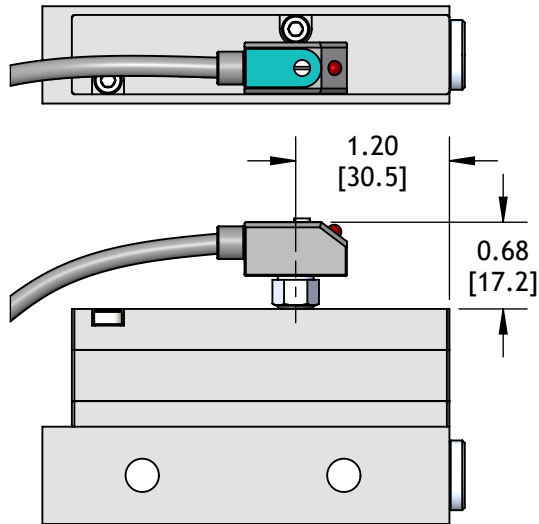

Additional Weight: 1.74 oz [49.4 g]

AX Series Vacuum Pump Manifolds

AX Series Vacuum Pumps can be used as a multi pump module manifold. All of our G 1/8 NPSF bases with integral filters (F18 models) can be used in these manifolds. To order a manifold, first, select your AX Manifold End Plate assembly. Next, decide which AX Manifold Pump Module(s) you'd like to use. Order each module as a separate line item and provide instructions for the order in which you'd like your manifold to be assembled.

AX Manifold End Plate

Threads		Air-Supply Options		Number of Modules		Silencer Options ¹	
AX-E	N	C		5		-2ST90	
N	NPTF	C	Common	1	1 Station	(Blank)	None
G	G	S	Separate	2	2 Stations	-ST	1 STC12M
				3	3 Stations	-2ST ¹	2 STC12M
				4	4 Stations	-ST90	1 STB38M w/ 90° Adapter
				5 ¹	5 Stations	-2ST90 ¹	2 STB38M w/ 90° Adapter
				6 ¹	6 Stations		
				7 ¹	7 Stations		
				8 ¹	8 Stations		
				9 ¹	9 Stations		
				10 ¹	10 Stations		

¹Use two silencers for 5+ stations.

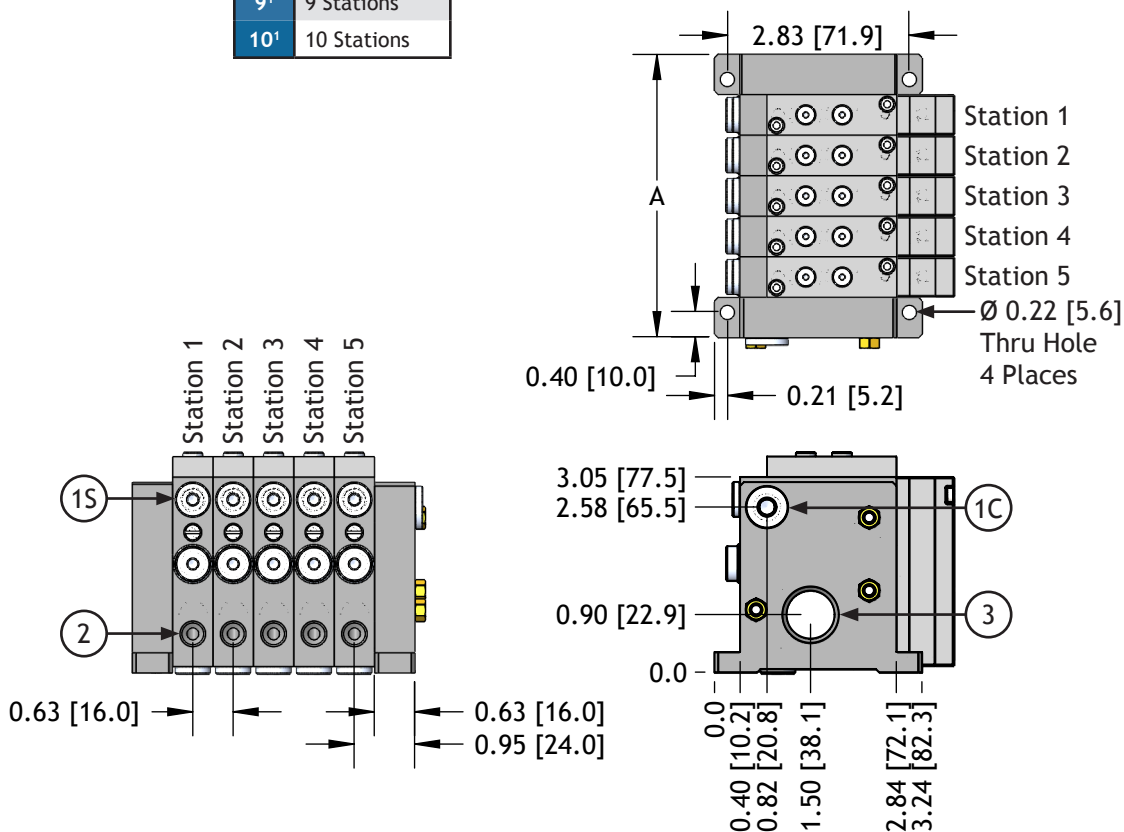
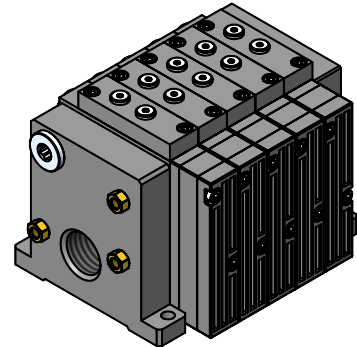

Capacity	A in [mm]	Weight oz [g]
1	1.98 [48.0]	9.96 [282.3]
2	2.52 [64.0]	10.22 [289.6]
3	3.15 [80.0]	10.48 [297.0]
4	3.78 [96.0]	10.74 [304.4]
5	4.41 [112.0]	10.65 [301.9]
6	5.04 [128.0]	10.91 [309.3]
7	5.67 [144.0]	11.17 [316.6]
8	6.30 [160.0]	11.43 [324.0]
9	6.93 [176.0]	11.69 [331.4]
10	7.56 [192.0]	11.95 [338.7]

Code	Function	NPT	G
1C	Main Air Supply - Common	1/4 NPTF	G 1/4
1S	Main Air Supply - Separate	G 1/8 NPSF	
2	Vacuum	G 1/8 NPSF	
3	Exhaust - Common	G 1/2 NPSF	

AX Series Vacuum Pump Manifold Module

Series		Capacity		Non-Return Option		Air-Supply		Module Style		Sensor Option	
AX	L	1	N	-	C	18	18	Standard	(Blank)	None	
L	L Series	1	1 Ejector	(Blank)	No	C	Common	18	Standard	(Blank)	None
M	M Series	2	2 Ejectors	R	Non-Return	S	Separate	18PS	Piloted Supply	-VA3	VA-3
								18PSB	Piloted Supply & Blow-Off	-VN3	VN-3
								18S24D	Solenoid Supply	-VN4	VN-4
								18SB24D	Solenoid Supply & Blow-Off	-VP4	VP-4
								18OS24D	Solenoid Supply (N.O.)	-61N	DVN-61-18M
								18OSB24D	Solenoid Supply (N.O.) & Blow-Off	-61P	DVP-61-18M
										-62N	DVN-62-18M
										-100N ¹	DVN-100
										-100P ¹	DVP-100

¹100 Series switches are too wide for use on adjacent modules.

AX Manifold Silencer Options

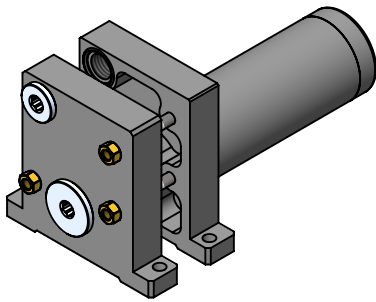

-ST
Additional Weight: 3.36 oz [95.3 g]

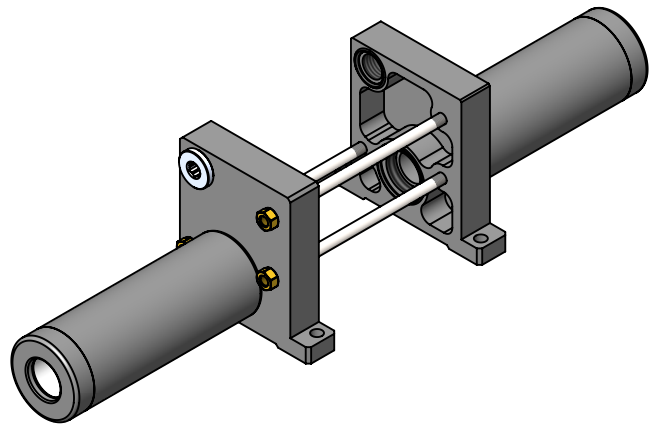

-2ST
Additional Weight: 6.72 oz [190.6 g]

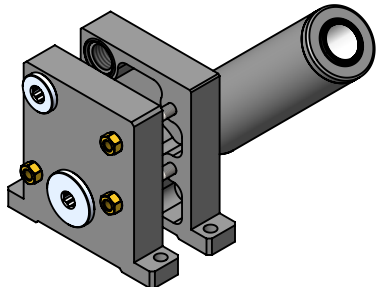

-ST90
Additional Weight: 4.03 oz [114.4 g]

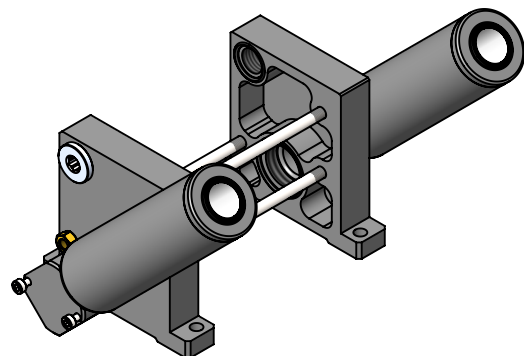

-2ST90
Additional Weight: 8.06 oz [228.8 g]

AX-M Series Vacuum Pumps - Performance

AX-M series pumps are optimized for operation at 50 psi (3.5 bar) air-supply pressure. Performance data at any other air pressure is shown solely for reference and serves only to demonstrate the affect of operation at non-optimal air pressures. Do not expect identical performance to tabulated data.

Graphs and tables show performance data at standard atmospheric conditions of 59° F (15° C) and 29.92 inHg (760 mmHg). Attainable vacuum levels will decrease with an increase in elevation or temperature.

SCFM Scale

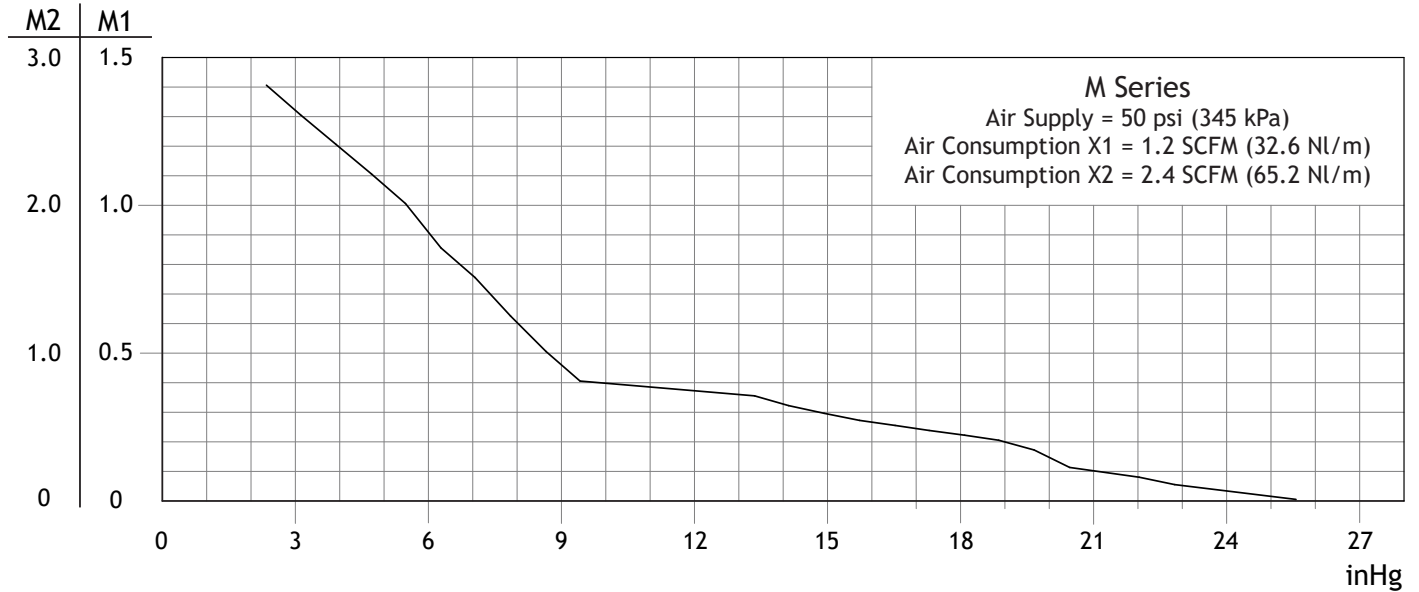

SCFM Scale

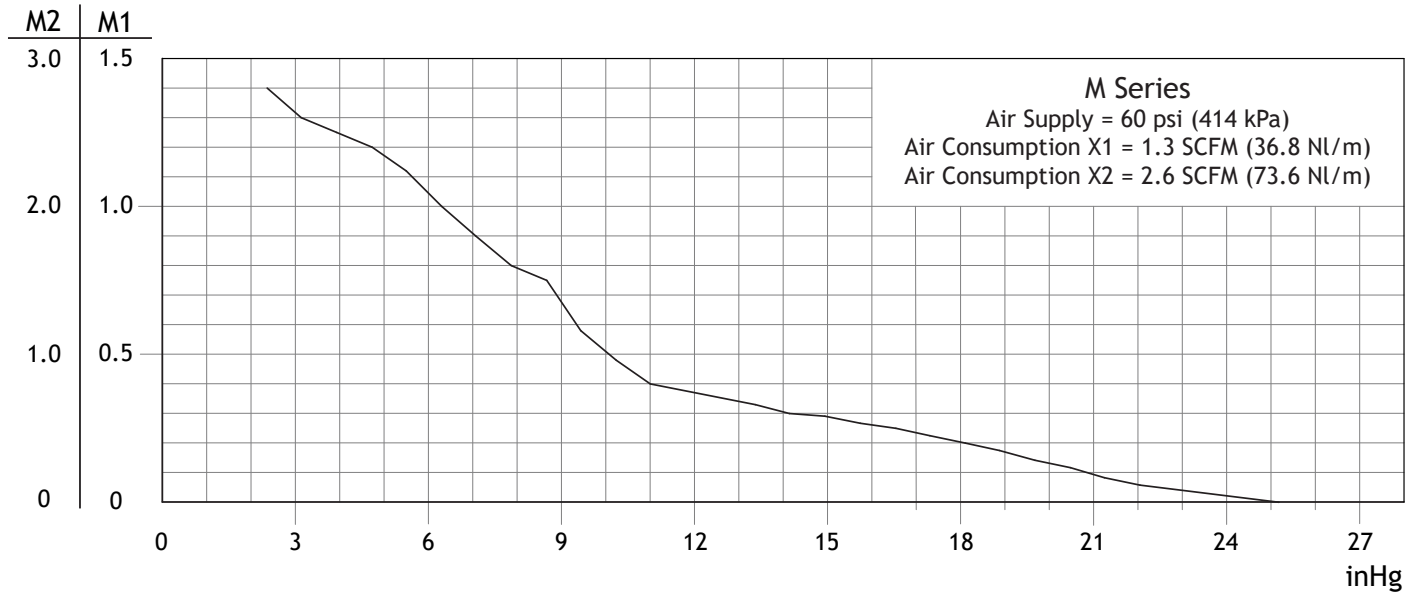

All performance data presented is a representation of production pumps but is not a guarantee due to variations in local barometric pressure and of mass produced components.

AX Series Vacuum Pumps - Performance

SCFM Scale

M2	M1
----	----

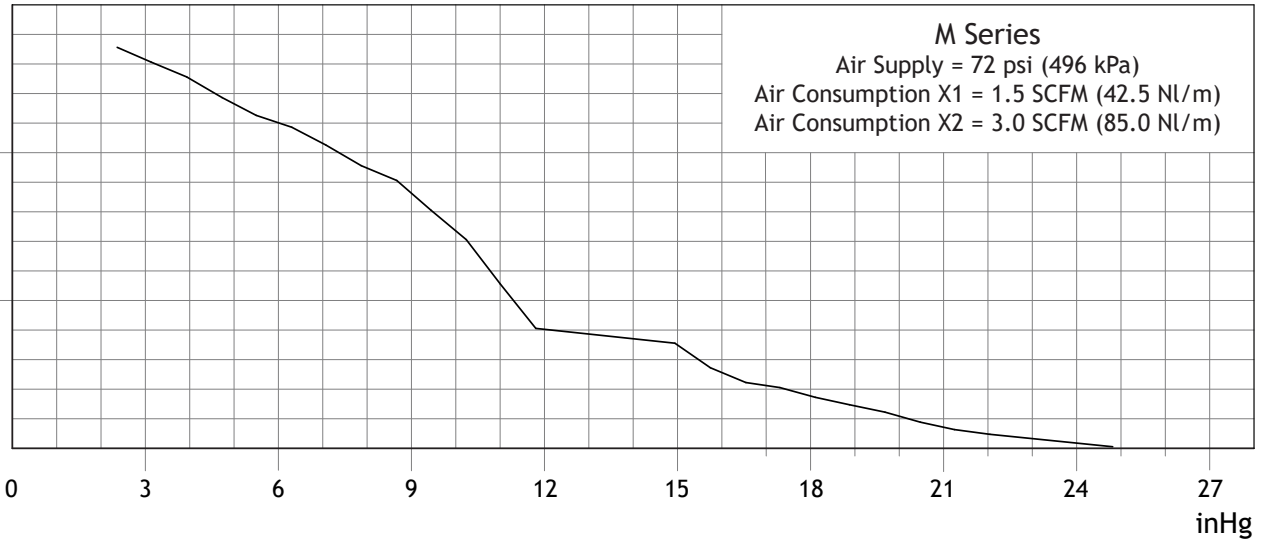
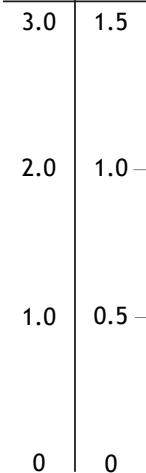

SCFM Scale

M2	M1
----	----

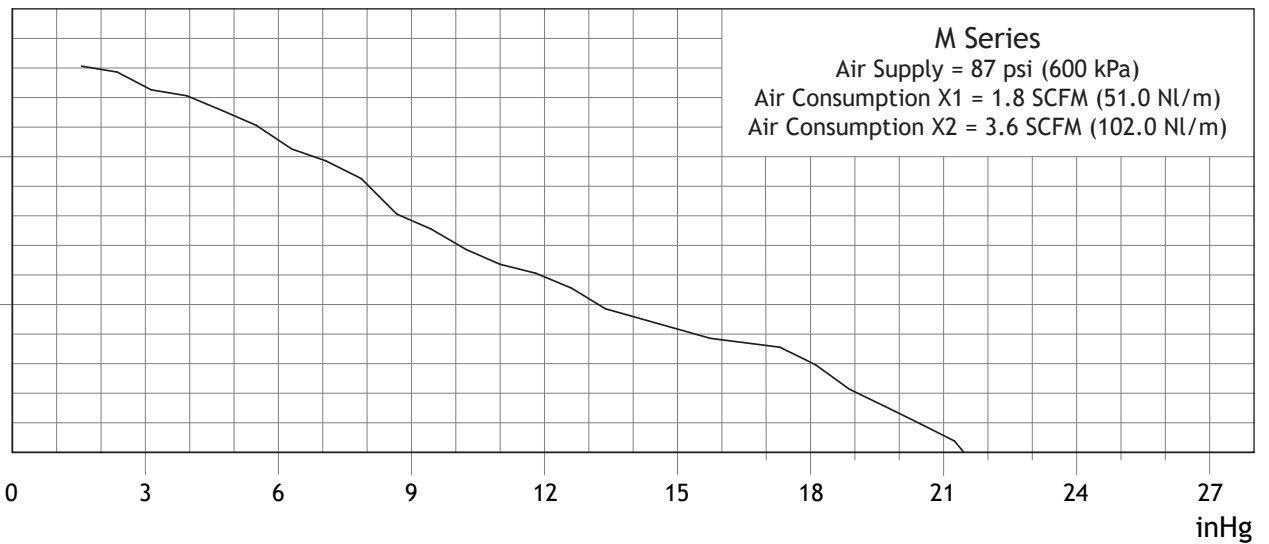
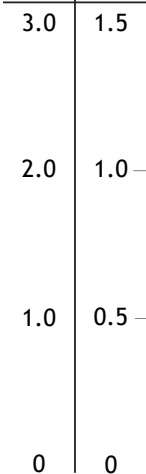

All performance data presented is a representation of production pumps but is not a guarantee due to variations in local barometric pressure and of mass produced components.

AX-L Series Vacuum Pumps - Performance

AX-L series pumps are optimized for operation at 87 psi (6.0 bar) air-supply pressure. Performance data at any other air pressure is shown solely for reference and serves only to demonstrate the affect of operation at non-optimal air pressures. Do not expect identical performance to tabulated data.

Graphs and tables show performance data at standard atmospheric conditions of 59° F (15° C) and 29.92 inHg (760 mmHg). Attainable vacuum levels will decrease with an increase in elevation or temperature.

SCFM Scale

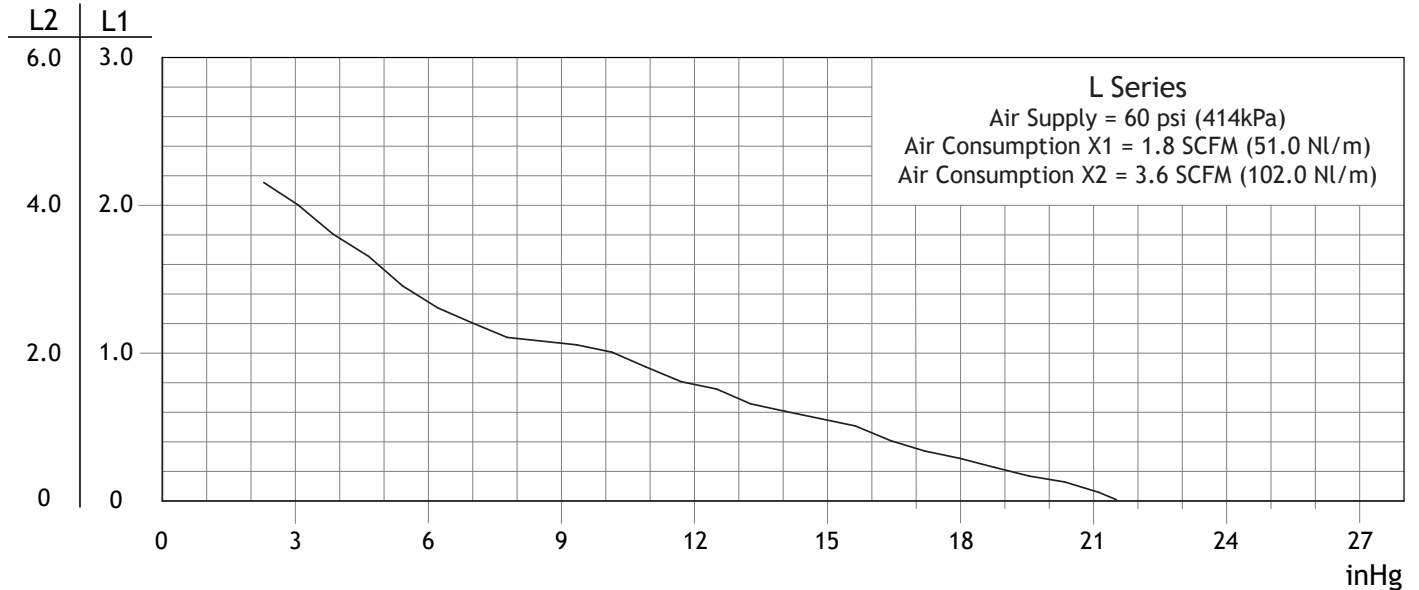

SCFM Scale

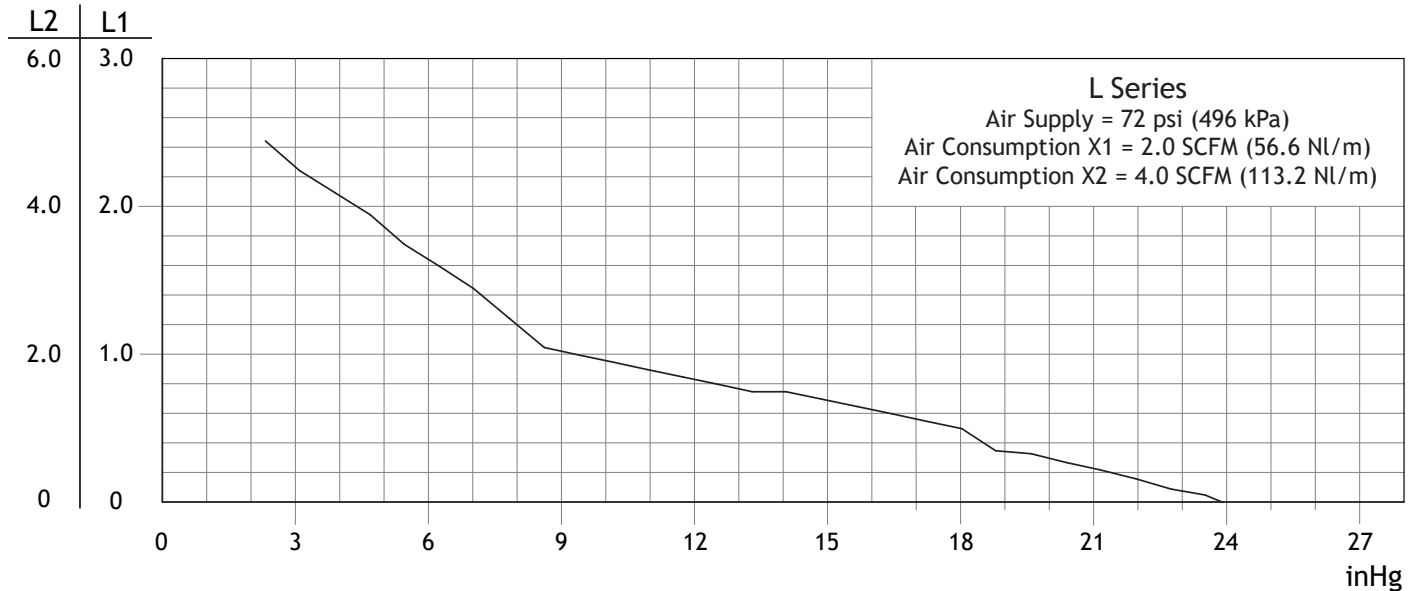

All performance data presented is a representation of production pumps but is not a guarantee due to variations in local barometric pressure and of mass produced components.

AX Series Vacuum Pumps - Performance

SCFM Scale

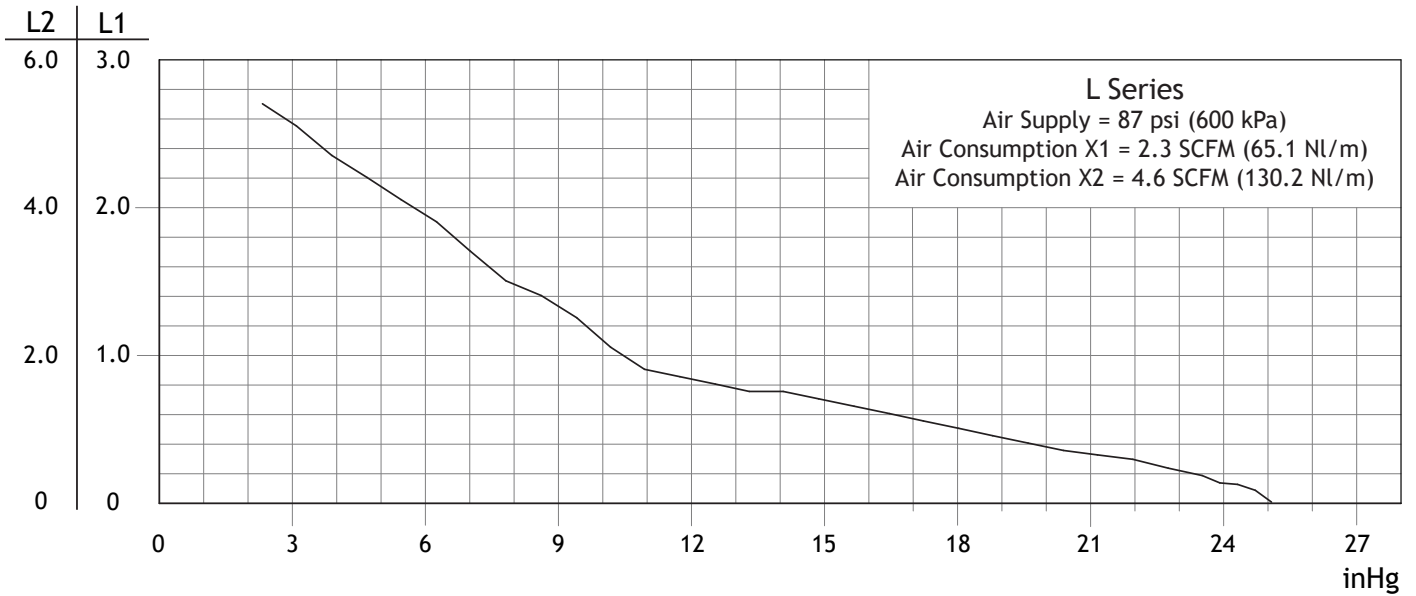

Vacuum Flow - SCFM

Model	Air Supply PSI	Air Cons. SCFM	Max Vacuum inHG	SCFM at Vacuum Level							
				3 inHG	6 inHG	9 inHG	12 inHG	15 inHG	18 inHG	21 inHG	24 inHG
AXM1N	50	1.2	25.5	1.30	0.91	0.46	0.37	0.29	0.22	0.10	0.03
AXM1N	60	1.3	25.1	1.32	1.00	0.67	0.37	0.29	0.20	0.10	0.02
AXM1N	72	1.5	24.8	1.31	1.10	0.86	0.40	0.34	0.17	0.06	0.01
AXM1N	87	1.8	21.4	1.23	1.05	0.78	0.59	0.41	0.30	0.05	0.004
AXL1N	60	1.8	21.6	2.03	1.35	1.06	0.79	0.55	0.29	0.07	-
AXL1N	72	2.0	24.0	2.28	1.65	1.03	0.84	0.70	0.51	0.24	-
AXL1N	87	2.3	25.1	2.57	1.95	1.30	0.84	0.70	0.51	0.33	0.13

SCFM X 28.32 = nl / m

Evacuation Time - sec / 100 in³

Model	Air Supply PSI	Air Cons. SCFM	Max Vacuum inHG	Seconds to Vacuum Level							
				3 inHG	6 inHG	9 inHG	12 inHG	15 inHG	18 inHG	21 inHG	24 inHG
AXM1N	50	1.2	25.5	0.43	0.50	0.57	1.82	3.1	5.3	9.3	18.3
AXM1N	60	1.3	25.1	0.43	0.47	0.91	1.67	2.9	4.9	8.7	16.9
AXM1N	72	1.5	24.8	0.20	0.48	0.89	1.57	2.7	4.6	8.3	16.1
AXM1N	87	1.8	21.4	0.15	0.50	0.94	1.62	2.7	4.5	8.0	15.7
AXL1N	60	1.8	21.6	0.12	0.31	0.61	1.07	1.8	3.1	5.5	-
AXL1N	72	2.0	24.0	0.11	0.27	0.53	0.96	1.6	2.7	4.7	9.2
AXL1N	87	2.3	25.1	0.10	0.24	0.47	0.84	1.5	2.4	4.3	8.1

sec / 100 in³ X 0.61 = sec / l

All performance data presented is a representation of production pumps but is not a guarantee due to variations in local barometric pressure and of mass produced components.