

# SECTION 15

## AIR AMPLIFIERS & TRANSFER PUMPS

## AIR AMPLIFIER

CD-style pumps use the Coanda effect to draw in large volumes of ambient air in relation to the small amount of compressed air consumed.

Applications include: blow-drying, ventilation and handling highly porous but lightweight parts.

The Coanda principle employs a nozzle that causes high velocity compressed air to cling to its shaped airfoil wall. Ambient air is drawn into the inlet and down into the center of the vortex formed by the Coanda nozzle so that the discharge air flow at the exhaust is much greater than the compressed air consumption.

Loosen the jam nut and turn the Coanda nozzle clockwise, by hand, until it stops, indicating the throat is fully closed. Supply regulated compressed air to the side air supply port and gradually rotate the Coanda nozzle to increase the throat gap until the desired vacuum level or discharge flow is achieved. To minimize air consumption, use the lowest pressure air supply that will yield the desired results. Higher air pressure will increase the airflow but will also increase air consumption. Turning the Coanda nozzle too far open will suddenly cause air flow to reverse direction and the pump will not perform properly.

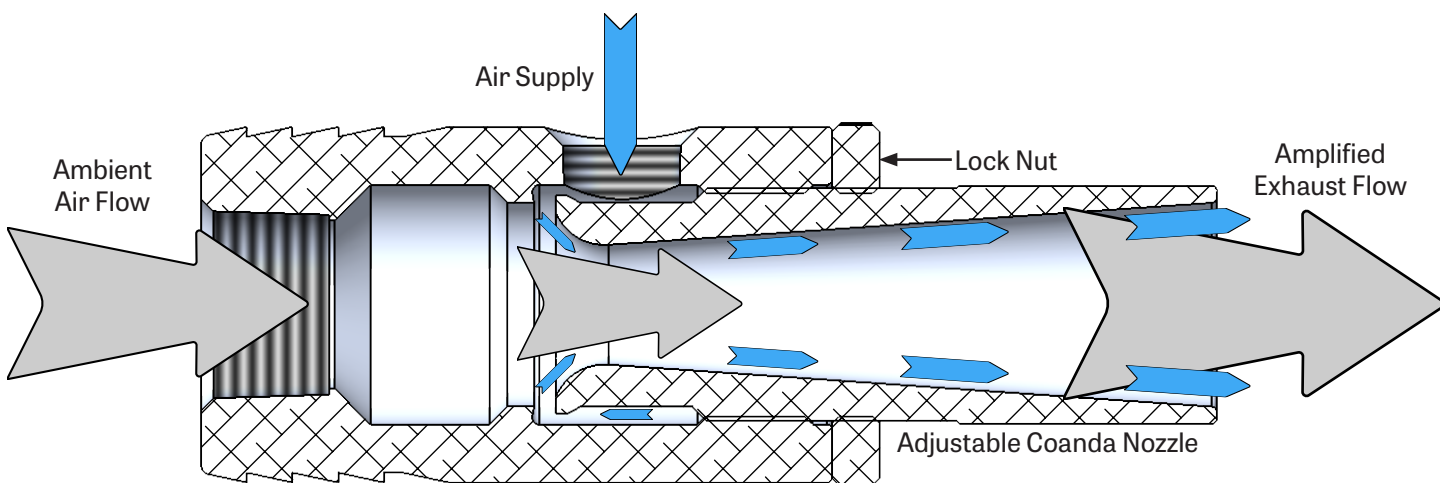

MODEL	I.D. in (mm)	AIR SUPPLY @ 80 PSI (5.5 bar)		
		INPUT FLOW SCFM [Nl/min]	OUTPUT FLOW SCFM [Nl/min]	VELOCITY ft/s [m/s]
CD-500HG CD-500H	0.5 (13)	9 [255]	75 [2124]	910 [277]
		5 [142]	42 [1189]	530 [162]
		3 [85]	22 [623]	265 [81]

### CD-500H

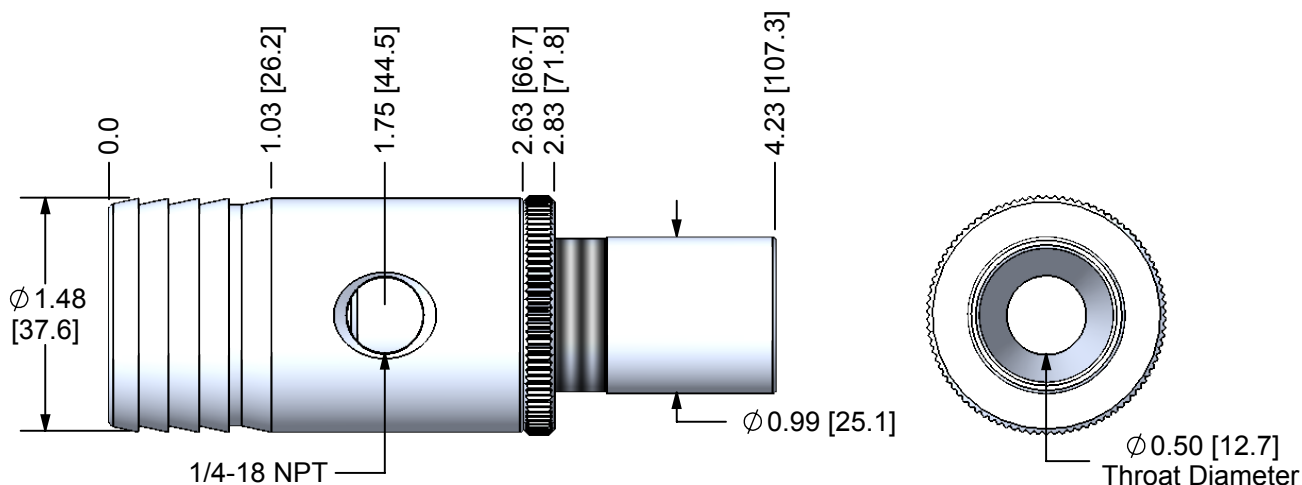

All performance data presented is a representation of production pumps but is not a guarantee due to variations in local barometric pressure and of mass produced components.

## AIR AMPLIFIER CD-500HG

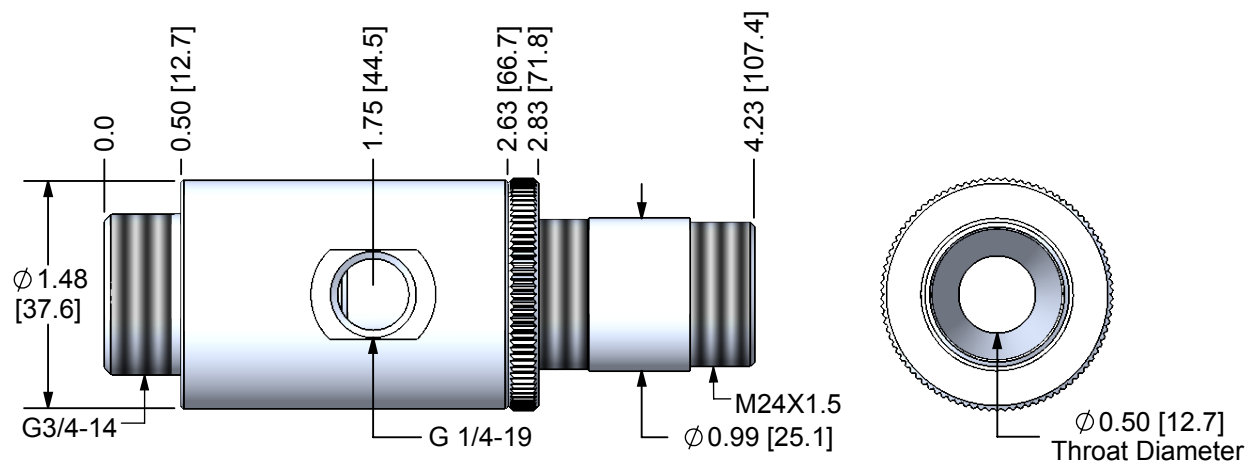

## TRANSFER PUMPS D-SERIES MATERIAL TRANSFER PUMPS

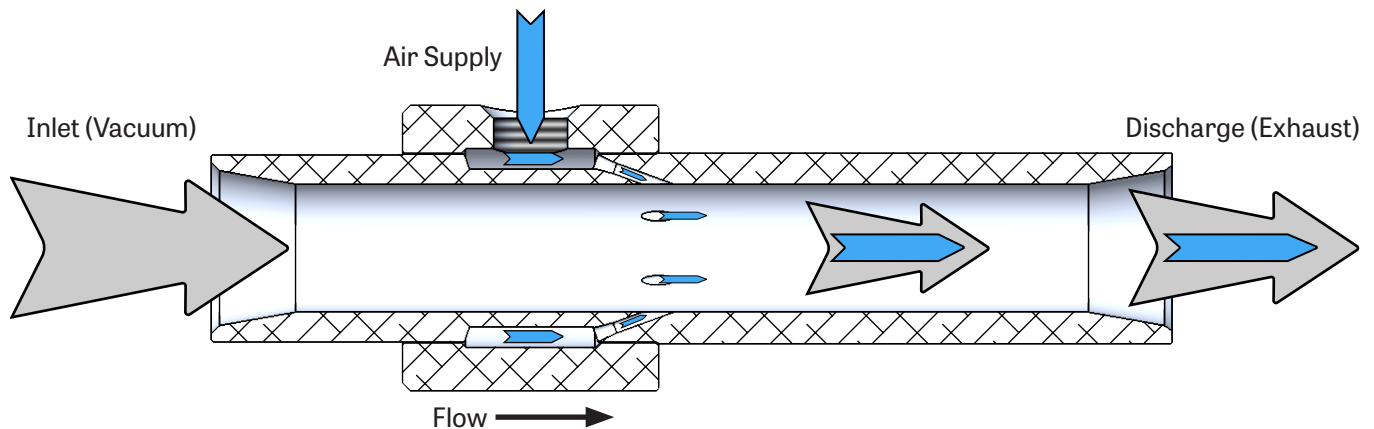

Direct Transfer Pumps use high velocity compressed air to generate a vacuum in the inlet of a smooth bore tubular body to draw in bulk dry goods and then convey it in a turbulent air stream through a hose attached to the discharge end of the pump. Plastic pellets, powders, beans, peas, sawdust, and continuous fabric trimmings are only a few examples of the numerous items that can be transferred.

These versatile pumps can also be used to convey small parts from an assembly station at much lower cost than a pick and place device. Select a pump inner diameter that is a little larger than the part's outer diameter then provide generous bends in the discharge hose for free passage of parts. For longer parts, select a pump (and discharge hose) diameter large enough to pass the part diameter but not large enough for the part length. This method will eliminate end-over-end tumbling that can damage parts. At the hose discharge end, direct the parts against hanging curtains or foam rubber to decelerate parts.

Vacuum flow rate, and thus material transfer rate, is easily controlled by simply changing the compressed air supply pressure. Higher air pressure increases the transfer rate. When shutting the pump off, it is good practice to let the pump blow air for a long enough period to allow all parts in the discharge hose to exit.

Compressed air is supplied to the body port and passes through an annular ring to several nozzles leading into the transfer tube at an angle. The nozzles concentrate the air stream so that it increases to maximum velocity as it passes through the nozzle throat and into the pump transfer tube. The air jets meet in the center and create a powerful vacuum at the tube inlet and a turbulent, spiraling flow at the discharge end. Large quantities of ambient air are ingested along with the material being transferred and, combined with nozzle air, helps to move material through the discharge hose.

# TRANSFER PUMPS

## D-SERIES MATERIAL TRANSFER PUMPS

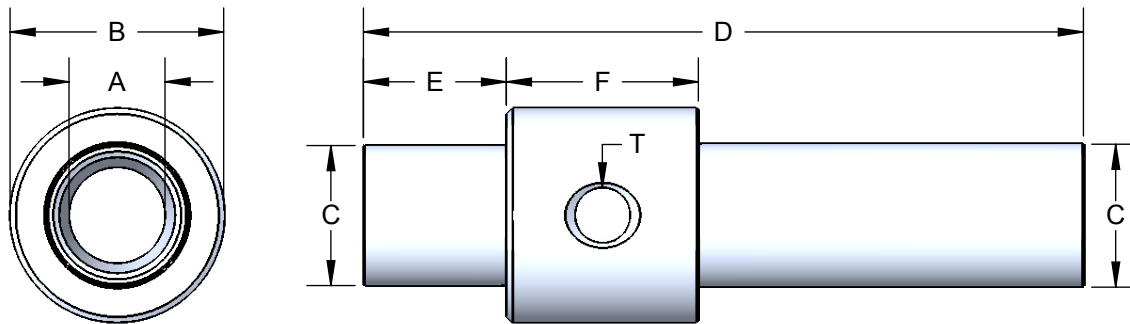

MODEL	A THROAT I.D. in [mm]	B COLLAR O.D. in [mm]	C TUBE O.D. in [mm]	D LENGTH in [mm]	E OFFSET in [mm]	F COLLAR WIDTH in [mm]	T SUPPLY THREAD
D2-3	0.25 [6.35]	1.25 [31.8]	0.75 [19.1]	3.5 [88.9]	0.75 [19.1]	1.0 [25.4]	1/8
D3-3	0.375 [9.5]	1.25 [31.8]	0.75 [19.1]	3.5 [88.9]	0.75 [19.1]	1.0 [25.4]	1/8
D3-6	0.375 [9.5]	1.25 [31.8]	0.75 [19.1]	3.5 [88.9]	0.75 [19.1]	1.0 [25.4]	1/8
D5-3	0.5 [12.7]	1.5 [38.1]	1.0 [25.4]	5.5 [140]	1.0 [25.4]	1.25 [31.8]	1/4
D5-6	0.5 [12.7]	1.5 [38.1]	1.0 [25.4]	5.5 [140]	1.0 [25.4]	1.25 [31.8]	1/4
D7-3	0.75 [19.1]	2.0 [50.8]	1.25 [31.8]	7.5 [191]	1.5 [38.1]	2.0 [50.8]	3/8
D7-6	0.75 [19.1]	2.0 [50.8]	1.25 [31.8]	7.5 [191]	1.5 [38.1]	2.0 [50.8]	3/8
D10-3	1.0 [25.4]	2.25 [57.2]	1.5 [38.1]	7.5 [191]	1.5 [38.1]	2.0 [50.8]	3/8
D10-6	1.0 [25.4]	2.25 [57.2]	1.5 [38.1]	7.5 [191]	1.5 [38.1]	2.0 [50.8]	3/8
D15-3	1.5 [38.1]	2.75 [69.9]	2.0 [50.8]	7.5 [191]	1.5 [38.1]	2.0 [50.8]	3/8
D15-6	1.5 [38.1]	2.75 [69.9]	2.0 [50.8]	7.5 [191]	1.5 [38.1]	2.0 [50.8]	3/8
D20-3	2.0 [50.8]	3.25 [82.6]	2.5 [63.5]	7.5 [191]	1.5 [38.1]	2.0 [50.8]	3/8
D20-6	2.0 [50.8]	3.25 [82.6]	2.5 [63.5]	7.5 [191]	1.5 [38.1]	2.0 [50.8]	3/8

MODEL	I.D. in [mm]	AIR VELOCITY ft/s [m/s]	VACUUM FLOW SCFM [NI/m]	VACUUM LEVEL inHG [mmHG]	AIR CONSUMPTION SCFM (NI/m)	
					@ 40 psi	@ 80 psi
D2-3	0.25 [6.35]	490 [149]	10 [283]	8 [203]	3.1 [87.8]	6 [170]
D3-3	0.375 [9.5]	328 [100]	15 [425]	6 [152]	3.5 [99.1]	6 [170]
D3-6	0.375 [9.5]	393 [120]	18 [510]	8 [203]	5.8 [164]	10 [283]
D5-3	0.5 [12.7]	306 [93.3]	25 [708]	3 [76]	5.2 [147]	9 [255]
D5-6	0.5 [12.7]	362 [110]	30 [850]	10 [254]	14 [396]	24 [680]
D7-3	0.75 [19.1]	272 [82.9]	50 [1416]	4.3 [109]	14 [396]	24 [680]
D7-6	0.75 [19.1]	326 [99.4]	60 [1699]	8 [203]	28 [793]	48 [1359]
D10-3	1.0 [25.4]	229 [69.8]	75 [2124]	3 [76]	14 [396]	24 [680]
D10-6	1.0 [25.4]	290 [88.4]	95 [2690]	5.8 [147]	28 [793]	48 [1359]
D15-3	1.5 [38.1]	224 [68.3]	165 [4672]	1.3 [33]	14 [396]	24 [680]
D15-6	1.5 [38.1]	272 [82.9]	200 [5663]	2.5 [64]	28 [793]	48 [1359]
D20-3	2.0 [50.8]	183 [55.8]	240 [6796]	0.8 [20]	14 [396]	24 [680]
D20-6	2.0 [50.8]	229 [69.8]	300 [8495]	1.5 [38]	28 [793]	48 [1359]

All performance data presented is a representation of production pumps but is not a guarantee due to variations in local barometric pressure and of mass produced components.